



HD/SD 15-inch LCD Monitor

DM-3016-F

Instruction Manual

Ver.1.00



HD/SD 15-inch LCD Monitor

DM-3016-F
Instruction Manual

2006.9

Ver.1.00

ASTRODESIGN,Inc

CONTENTS

CONTENTS	i
INTRODUCTION	v
SAFETY PRECAUTIONS	v
Concerning the monitor	v
Concerning the power cord	v
Concerning foreign matter	v
Concerning the power supply and grounding	vi
Concerning the liquid crystal	vii
Concerning impact	vii
Concerning the installation and operation locations	viii
CONCERNING THE DM-3016-F	1
Outline of DM-3016-F	1
PARTS AND THEIR FUNCTIONS	3
2.1 DM-3016-F front panel view and parts	3
2.2 DM-3016-F rear panel view and parts	6
OPERATION	9
3.1 Connection procedure	9
3.2 Usage	9
3.3 Concerning the screen displays	10
3.3.1 Regular screen	10
3.3.2 Menu screen	13
3.3.3 Format selection screen	14
3.3.4 LCD adjustment screen	15
3.3.5 Marker setting screen	16
3.3.6 Front switch function allocation screen	17
3.3.7 User settings save and load screen	18
3.3.8 Display information selection screen	19
3.3.9 Input signal name setting screen	20
3.3.10 Aspect ratio selection screen	21
3.3.11 Remote controller setting screen	22
3.3.12 Audio level meter display setting screen	23
3.3.13 Other functions setting screen	24
3.3.14 Reset screen	26
3.3.15 Infrared remote control ID setting screen	27
3.4 Description of functions and operating procedures	28
3.4.1 Selecting the input signals	28
3.4.2 Selecting the format	29
3.4.3 Selecting the aspect ratio	29
3.4.4 Setting the aspect ratio	30
3.4.5 Selecting the monochrome display or color display	30
3.4.6 Selecting the blue only or color display	31

3.4.7	Displaying the markers	31
3.4.8	Selecting the markers to be displayed	32
3.4.9	Adjusting the box marker display position	33
3.4.10	Adjusting the box marker size	33
3.4.11	Adjusting the user marker display position	34
3.4.12	Setting the marker thickness	34
3.4.13	Adjusting the offset level of the brightness signals	34
3.4.14	Adjusting the contrast of the brightness signals	35
3.4.15	Adjusting the Pb (Cb) value	35
3.4.16	Adjusting the Pr (Cr) value	36
3.4.17	Adjusting the Pb (Cb) and Pr (Cr) values simultaneously (adjusting the chroma)	36
3.4.18	Multiplying the chroma signal value by 3	37
3.4.19	Adjusting the peaking value	37
3.4.20	Setting peaking ON/OFF	38
3.4.21	Adjusting the hue	38
3.4.22	Setting the filter ON/OFF	39
3.4.23	Lighting the tally lamps	40
3.4.24	Selecting the tally display method	40
3.4.25	Selecting the channels to be displayed by the audio level meter	40
3.4.26	Selecting the audio level meter display format	41
3.4.27	Selecting color display or monochrome display for the audio level meter	41
3.4.28	Selecting the audio level meter channel layout	42
3.4.29	Setting the audio level meter frame and information ON/OFF	42
3.4.30	Switching the audio level meter display ON/OFF	43
3.4.31	Switching the time code display ON/OFF	43
3.4.32	Switching the input signal ID display ON/OFF	43
3.4.33	Switching the format display ON/OFF	44
3.4.34	Switching the error status display ON/OFF	44
3.4.35	Setting the mask	45
3.4.36	Selecting the color space	45
3.4.37	Setting Green ON/OFF	46
3.4.38	Setting Blue ON/OFF	46
3.4.39	Setting Red ON/OFF	46
3.4.40	Setting H Delay ON/OFF	47
3.4.41	Setting V Delay ON/OFF	47
3.4.42	Allocating functions to the front panel switches	47
3.4.43	Setting the remote controllers	48
3.4.44	Giving names to the input signals	49
3.4.45	Displaying the color bars when no signals are input	49
3.4.46	Executing the NTSC setup	50
3.4.47	Saving and calling the settings	50
3.4.48	Returning the settings to their initial values	51
3.4.49	Selecting the color temperature	52

3.4.50	Adjusting the G brightness	52
3.4.51	Adjusting the B brightness	53
3.4.52	Adjusting the R brightness	53
3.4.53	Adjusting the G contrast.....	53
3.4.54	Adjusting the B contrast	54
3.4.55	Adjusting the R contrast.....	54
3.4.56	Adjusting the G gamma	54
3.4.57	Adjusting the B gamma	55
3.4.58	Adjusting the R gamma.....	55
3.4.59	Adjusting the output volume level	55
3.4.60	Setting the output audio channel.....	56
3.4.61	Changing the color of the markers	56
3.4.62	Changing the color of the time code	56
3.4.63	Changing the color of the characters	57
3.4.64	Displaying all the settings.....	57
MAIN SPECIFICATIONS		59
4.1	Input formats	59
4.2	Input signal systems.....	60
4.3	Display systems	60
4.4	Headphones output format.....	61
4.5	Concerning the adjustment values	62
4.6	Concerning the aspect ratios	64
4.7	Concerning the audio level meter	65
4.7.1	Audio levels and cell color scheme	65
4.7.2	Display formats and cell layout	66
4.7.3	Audio level meter settings.....	68
4.8	Concerning the remote controllers	69
4.8.1	Examples of operations	69
4.8.2	Settings during level operations	70
4.9	Settings when initialization is performed	71
4.9.1	Common setting items	71
4.9.2	Setting items by channel.....	73
4.9.3	Resetting the error count and elapsed time	73
4.10	General specifications	74
4.11	Outline drawings	75
4.11.1	Outline drawings of DM-3016-F (main unit)	75
4.11.2	Outline drawing of self-standing plate (standard accessory).....	76
STANDARD AND OPTIONAL ACCESSORIES.....		77
5.1	Standard accessories.....	77
5.2	Optional accessories.....	77
MAINTENANCE AND OTHER PROCEDURES		79
When the monitor does not operate properly		79
No trouble or malfunctioning is indicated if any of the following situations should occur.....		80

When trouble or malfunctioning occurs 80

INTRODUCTION

Thank you very much for purchasing this model DM-3016-F HD LCD picture monitor.

This manual contains details on the operation procedures to be followed when the DM-3016-F is used, the checkpoints and precautions to be observed, and so on.

Before using the DM-3016-F, please read through these instructions to ensure that you will operate the monitor correctly.

After reading the instructions, keep them in a safe place for future reference.

SAFETY PRECAUTIONS

WARNING

Concerning the monitor

- Do not subject the monitor to strong shocks or throw it around. Doing so may cause the liquid crystal to leak and/or the monitor to malfunction, rupture, generate heat and cause a fire.
- Do not use the monitor wherever there is a risk of ignition or explosions.
- Do not place the monitor inside a microwave oven or other heating or cooking appliance or pressure vessel. Doing so may cause heat or smoke to be generated in the monitor, combustion and/or damage to the circuit components.
- Inside the monitor are some high-voltage parts: since exposure to these parts may result in electric shocks or burns, refrain from disassembling, repairing or remodeling the monitor.
- If there is a thunderstorm while the monitor is being used outdoors, immediately turn off its power, disconnect the power cord from the monitor, and move the monitor to a safe place.

Concerning the power cord

- Always take hold of the molded part of the plug when disconnecting the power cord.
- Do not use force to bend the power cord or bunch it up for use. Doing so may cause a fire.
- Do not place heavy objects on top of the power cord. Doing so may damage the cord, causing a fire or electrical shock.

Concerning foreign matter

- Do not spill liquids inside the monitor or drop inflammable objects or metal parts into it. Operating the monitor under these conditions may cause a fire, electric shocks and/or malfunctioning.

CAUTION

Concerning the power supply and grounding

- Use a supply voltage within the range of AC 100 to 240V (50/60 Hz) for the monitor.
- Ground the monitor through a 3-wire power cord with a grounding line.
- To ensure safety and also to avoid trouble and malfunctions, for use be absolutely sure to connect the monitor to a power outlet which is equipped with a grounding terminal for protection. If the monitor cannot be connected to such a power outlet, be absolutely sure to use the ground terminal to connect the monitor to ground before use.
- Do not turn the power back on immediately after having turned it off. Doing so can cause malfunctioning.
- Use a power supply for the monitor which is separate from that used for a copying machine or other equipment with a high power consumption or for equipment which generates noise. Otherwise, the monitor may not operate properly.
- Bear in mind that the sound may be adversely affected if the power supply for a microphone, amplifier, speaker system, etc. is used for the unit as well.

Concerning the liquid crystal

- **Due to the nature of liquid crystal, some picture elements may be missing (bright spots, flashing spots, etc.) at times.**

- **Do not touch any liquid crystal which has leaked from the liquid crystal panel.**

If the liquid crystal panel has been damaged inadvertently, and the liquid inside (liquid crystal) has leaked out, keep the liquid away from your mouth and skin and do not inhale its vapors. In the event that liquid crystal has made contact with your eyes or mouth, rinse it off with water immediately. If it has come into contact with your skin or clothing, wipe it off immediately with alcohol, and then wash it off with soap. Leaving it in place may damage your skin or clothing.

- **Exercise care with the glass of a broken liquid crystal panel.**

If the LCD panel has broken, take care not to cut your hands on the glass shards. If you should touch an area where the glass has broken off, you may injure yourself.

- **The LCD panel is a high-precision component and, as such, the following care must be taken in its handling.**

- Wiping the panel's surface with benzene, paint thinners, etc. will cause a deterioration in its quality.
- If water (salty water) is left on the display surface, discoloration and staining will result.
- Exposing the panel directly to ultraviolet rays for an extended period may cause the deflection panel to turn brown, in turn causing the contrast to drop and other forms of deterioration to develop in the display quality.
- Moisture inside the monitor due to condensation, etc. may cause unevenness in the colors.
- Directly tapping the surface or bumping it into objects may crack the panel, etc.
- Do not attempt to disassemble the panel since leaking liquid crystal may make contact with your skin, which is hazardous.

- **Handle the liquid crystal protective panel carefully.**

Carefully wipe off any fingerprints or dirt on the liquid crystal protective panel with a cleaning agent used to clean office automation equipment. Rubbing the panel with too much force may mark or damage the panel.

Concerning impact

- **This is a precision instrument and, as such, subjecting it to impact may cause malfunctioning. Take special care when moving the monitor.**
- **Do not drop the monitor.**

Concerning the installation and operation locations

■ Installing the monitor in the following kinds of locations may cause malfunctioning and/or accidents.

- Locations with an ambient temperature outside the range of 0 to 40°C (see Note 1)
- Locations with an ambient humidity outside the range of 30 to 80% RH
- Locations in the vicinity of an air conditioner or subject to rapid temperature changes or the formation of condensation
- Locations exposed to direct sunlight (see Note 2)
- Locations exposed to corrosive gases or high concentrations of dust
- Locations where strong magnetic fields are generated
- Locations where the monitor may be splashed with water, oil, chemicals, etc.
- Locations to which vibrations are transmitted from the floor
- Unstable locations

■ Take care to meet the following conditions in order to ensure that the monitor will be used properly.

- Do not place heavy objects such as another monitor on top of the monitor.
- Avoid placing any objects around the monitor.

Note 1: When the surface temperature of the LCD panel exceeds 60°C, the panel's backlight and other parts may be damaged.

Note 2: Exposing the panel directly to ultraviolet rays for an extended period may cause the deflection panel to turn brown, in turn causing the contrast to drop and other forms of deterioration to develop in the display quality.

1

CONCERNING THE DM-3016-F

The DM-3016-F is a slim, lightweight and portable LCD picture monitor which comes in handy for the monitoring and non-linear editing of the pictures shot during live broadcasts, on location or in studios, etc.

It comes with many different functions including ones for adjusting the brightness, contrast and chroma and displaying various markers. Its input signal support 23 HDTV video formats and two SDTV video formats.

Outline of DM-3016-F

- **15-inch a-Si TFT LCD panel featured**
(View angle: 170° to the left and right, 170° up and down; XGA: 1024 × 768)
- **Input of HD-SDI, SD-SDI, composite and component signals supported**
- **25 different video formats supported**
 - Standards complied with by HD-SDI signals: SMPTE292M, BTA S-004B (1.485 Gbps SDI input)
 - Standards complied with by SD-SDI signals: SMPTE259M (270 Mbps SDI input)
 - Standards complied with by component signals: BTA S-001B, SMPTE 274M, SMPTE 296M
 - Standards complied with by composite signals: SMPTE170M for NTSC,
ITU-R624-4 (excluding PAL-N and PAL-M) for PAL
- **SDI IN, SDI MONITOR OUT, COMPOSITE and COMPONENT connectors provided**
- **Functions for adjusting brightness, contrast, chroma, filter, monochrome and gamma**
- **Marker display functions**
(FRAME, CENTER, 95%, 93%, 88%, 80%, 4:3, 13:9, 14:9, 2.35:1, 1.85:1, 1.66:1, Grating, BOX, USER)
- **Setting of aspect ratio by user enabled**
(4:3, 16:9, Actual Size (HD only), Twice Size (SD only), Blanking, Under Scan)
- **Setting of front switches by user enabled**
(Aspect ratio selection, monochrome, blue-only, display/non-display of markers and chroma boosting function, etc.)
- **Setting of remote controller by user enabled**
(Input signal selection, marker ON/OFF selection, mask ON/OFF selection, etc.)
- **Automatic tracking of input signals possible**
- **Automatic 1/1.000 and 1/1.001 frame rate tracking and input signal detection functions**
- **LCD frequency conversion by frame conversion function**
- **Back light adjustment function**
- **Selection of 5500K, 6500K or 9300K color temperature possible (even more subtle color tone and gray scale adjustments possible)**
- **Functions for detecting audio errors and CRC/EDH errors for input channels provided**
- **Time code (VITC) display**

- 8 channel display of the audio level meters
- Function for customizing the audio level meters
- Functions for locking the panel switches and storing the settings
- Functions for storing settings as user data and calling such data
- Operation of all settings by dedicated infrared remote controller enabled
- Operation of multiple units using a single dedicated infrared remote controller possible
- Slim-line design and light weight
- AC power supply input supported (100 to 240V)

2

PARTS AND THEIR FUNCTIONS

2.1 DM-3016-F front panel view and parts

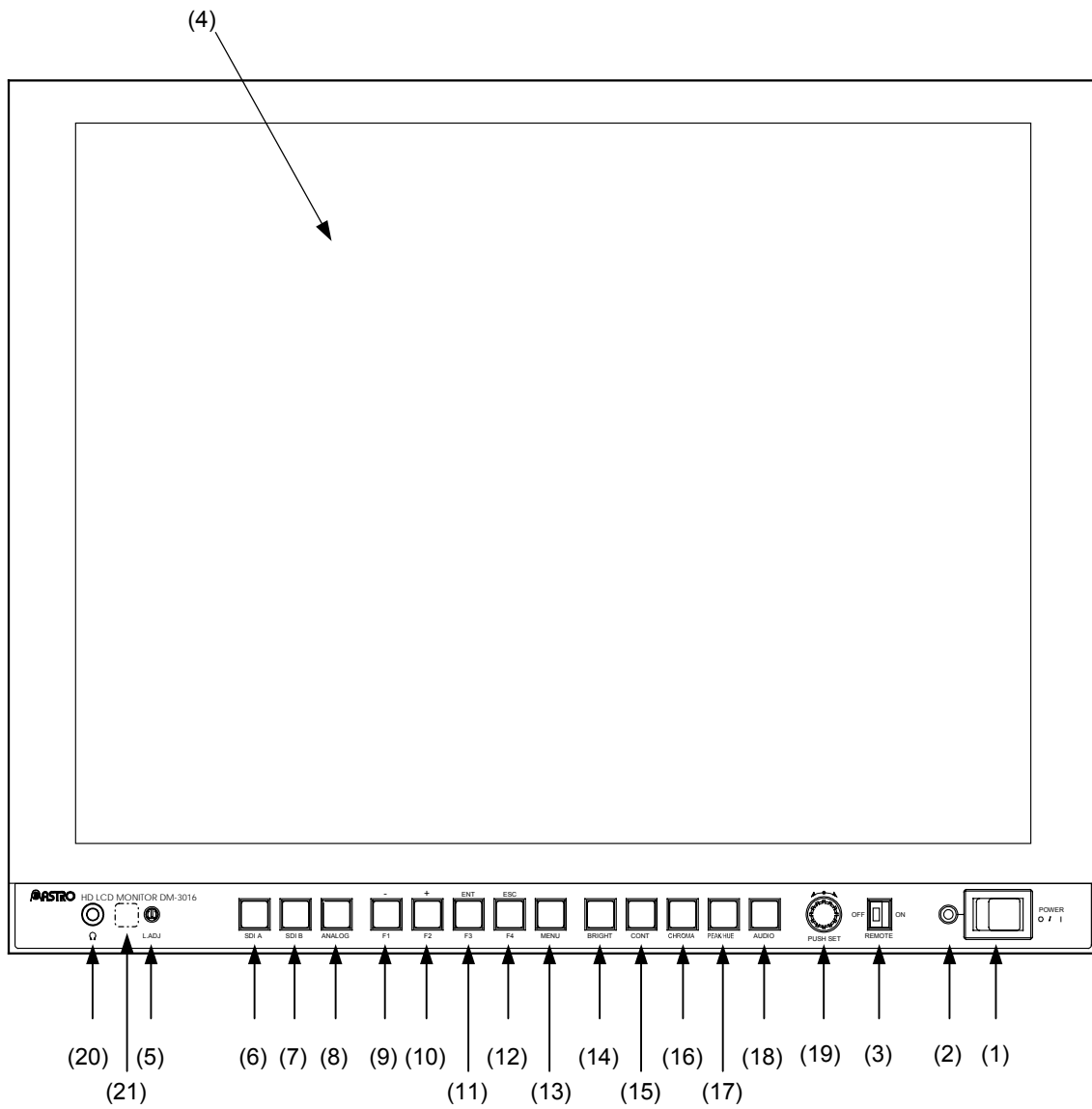

Fig. 2.1 Front panel view of DM-3016-F

Table 2.1 Front panel parts

No.	Part	Description of function
(1)	POWER switch/LED	Used to turn the power ON and OFF.(*1)
(2)	POWER LED	Lights up green while the power is on.
(3)	REMOTE switch/LED	Used to lock the panel switches and enable the monitor to be operated by remote control. (*3) The monitor's settings are saved at the same time as the panel switches are locked. <input checked="" type="checkbox"/> Wait appears at the bottom right of the screen while the settings are being saved. (*2) The saved settings are loaded when the power is turned on. (The LED lights up yellow while remote control is enabled.)
(4)	LCD display	This is where the images are displayed.
(5)	Adjustment control	Used to adjust the backlight of the LCD display. (*4)When it is turned clockwise, the display becomes brighter; conversely, when it is turned counterclockwise, it becomes darker.
(6)	SDI A switch	Used to display the images which are input to SDI input channel A on the screen.
(7)	SDI B switch	Used to display the images which are input to SDI input channel B on the screen.
(8)	ANALOG switch	Used to display the images which are input to the ANALOG on the screen. Each time ANALOG switch is pushed, image of COMPOSITE or COMPONENT are switched.
(9)	F1/- switch	Used to execute the function allocated to the switch at any time except during menu operations. (Refer to section 3.4.42.) During menu operations, the switch is used to move the cursor to the left or upward or reduce the value which is being adjusted.
(10)	F2/+ switch	Used to execute the function allocated to the switch at any time except during menu operations. (Refer to section 3.4.42.) During menu operations, the switch is used to move the cursor to the right or downward or increase the value which is being adjusted.
(11)	F3/ENT switch	Used to execute the function allocated to the switch at any time except during menu operations. (Refer to section 3.4.42.) During menu operations, the switch is used to enter the value which is being adjusted and move between hierarchical levels.
(12)	F4/ESC switch	Used to execute the function allocated to the switch at any time except during menu operations. (Refer to section 3.4.42.) During menu operations, the switch is used to cancel the value of the setting which is being changed and to exit the adjustment.
(13)	MENU switch	Used to turn the menu screen ON or OFF. When the menu screen is ON: Switches (9) to (12) function as the -, +, ENT and ESC switches, respectively. When the menu screen is OFF: Switches (9) to (12) function as the F1, F2, F3 and F4 switches, respectively.
(14)	BRIGHT switch	Used to adjust the brightness. (Refer to section 3.4.13.)
(15)	CONTRAST switch	Used to adjust the contrast. (Refer to section 3.4.14.)
(16)	CHROMA switch	At the YPbPr (ColorSpace) setting Used to adjust the chroma. Each time the switch is pressed, its setting changes in the following sequence: chroma → Pb → Pr → exit adjustment. (Refer to sections 3.4.15 to 3.4.17.)
		At the GBR (ColorSpace) setting The chroma cannot be adjusted.
(17)	PEAK/HUE switch	At the YPbPr (ColorSpace) setting Used to adjust the peak value or hue. The peak value can be adjusted when peaking is at ON. (Refer to sections 3.4.19 and 3.4.21.) Each time the switch is pressed, its setting changes in the following sequence: peak → hue → exit adjustment.
		At the GBR (ColorSpace) setting Used to adjust the peak value. The peak value can be adjusted when peaking is at ON. (Refer to section 3.4.19.) The hue cannot be adjusted.

(18)	AUDIO switch	Used to adjust the volume level of the output sound or set the output channel. Each time the switch is pressed, its setting changes in the following sequence: volume → left channel → right channel. If you press Audio switch more than 1 second, audio output will be MUTE. (*5)(Refer to sections 3.4.59 to 3.4.60.)
(19)	Adjustment dial	Used to adjust or select the settings.
(20)	Headphone jack	The sound carried on the input signals are output in stereo from this jack.
(21)	Infrared sensor	This receives the signals from the infrared remote control (RB-1666). (*3)

- *1 Do not turn on the power within 3 seconds after turn OFF the power. When you power on and off quickly power on may not be done properly.
- *2: Do not turn off the power while the setting saving process is in progress. If the power is turned off during this process, all the user data saved in the monitor will be destroyed, and the initial settings will be established when the power is next turned on.
- *3: When the REMOTE switch is set to ON, the remote control reception status is established. If the remote control is left unconnected when LEVEL control has been set for remote control, the remote control status will be judged to be open, and the settings selected so far may be changed. To prevent this, set the remote control allocations to NON, select Edge for the remote control status or take some other action.
- *4: When brightness is down by light control volume of LCD backlight, ripple power voltage may be generated. When you share DC power with other equipment, use as maximum brightness.
- *5 MUTE is canceled when Audio switch is pressed more than 1 second or re-adjustment of volume value is done

2.2 DM-3016-F rear panel view and parts

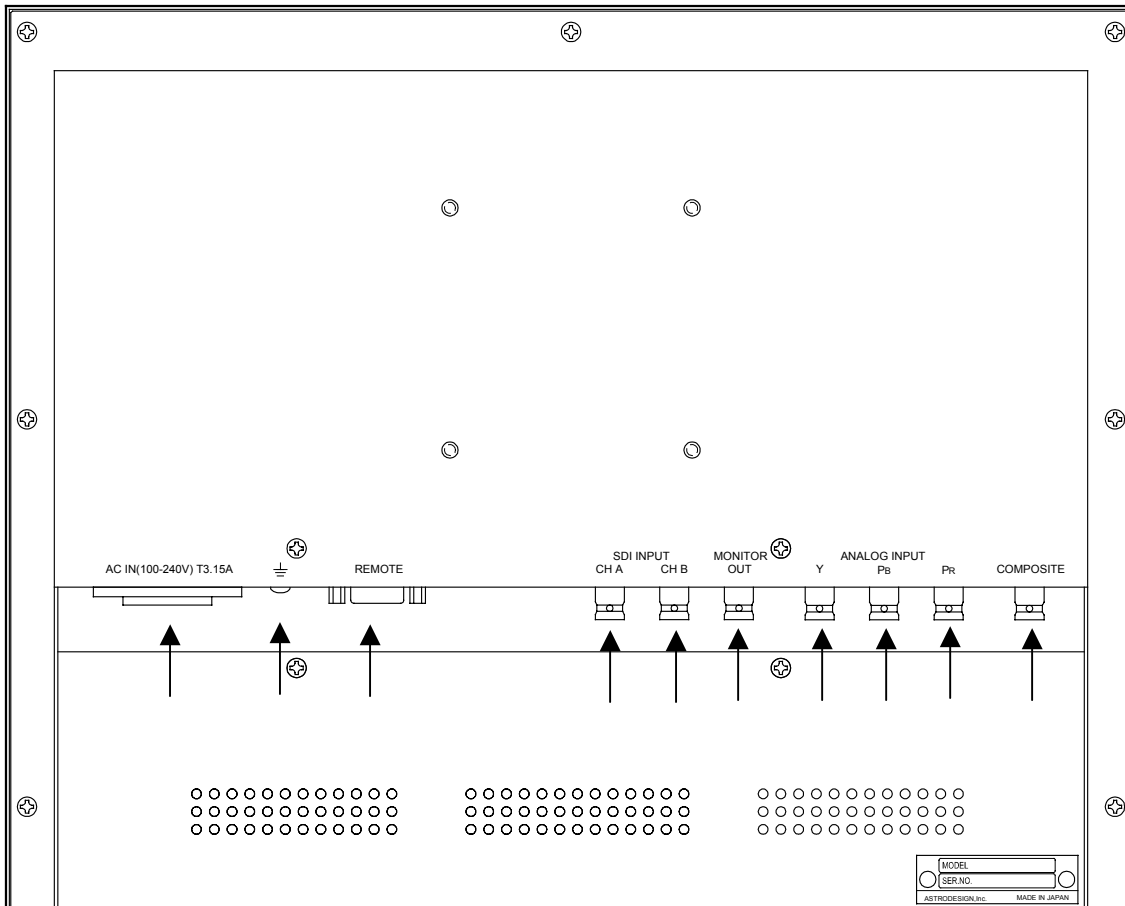

Fig. 2.2 Rear panel view of DM-3016-F

Table 2.2 Rear panel parts

No.	Part	Description of function
(1)	Power socket	AC 100V type of AC power socket (a 3-pin power cable is connected here).
(2)	Ground terminal	M3 screw, ground terminal
(3)	Remote connector (*1)	D-sub 9pin (female)
(4)	SDI IN A	HD-SDI, SD-SDI signal input connector
(5)	SDI IN B	HD-SDI, SD-SDI signal input connector
(6)	MONITOR OUT	Output connector for simplified monitoring of SDI input signals
(7)	COMPOSITE	Composite signal input connector.
(8)	Y IN	Component Y/G signal input connector. In case of component input, it takes sync with Y/G.
(9)	Pb IN	Component Pb/B signal signal input connector.
(10)	Pb OUT	Component Pr/R signal input connector.

*1: Remote connector ((3) in rear panel view)

The remote controller works only when the REMOTE switch is at the ON setting.
For details on the remote controller, refer to section 4.8.

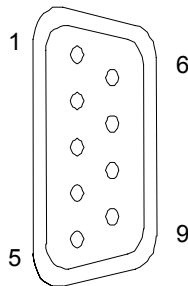

Pin No.	Signal	Initial value
1	GND	-
2	Remote Control TALLY (G)	-
3	Remote Control 1	Non
4	Remote Control 2	Non
5	GND	-
6	Remote Control 3	Non
7	Remote Control TALLY (R)	-
8	Remote Control 4	Non
9	Remote Control 5	Non

* The monitor may not operate properly unless pin 1 and pin 5 are connected to the same ground pin.

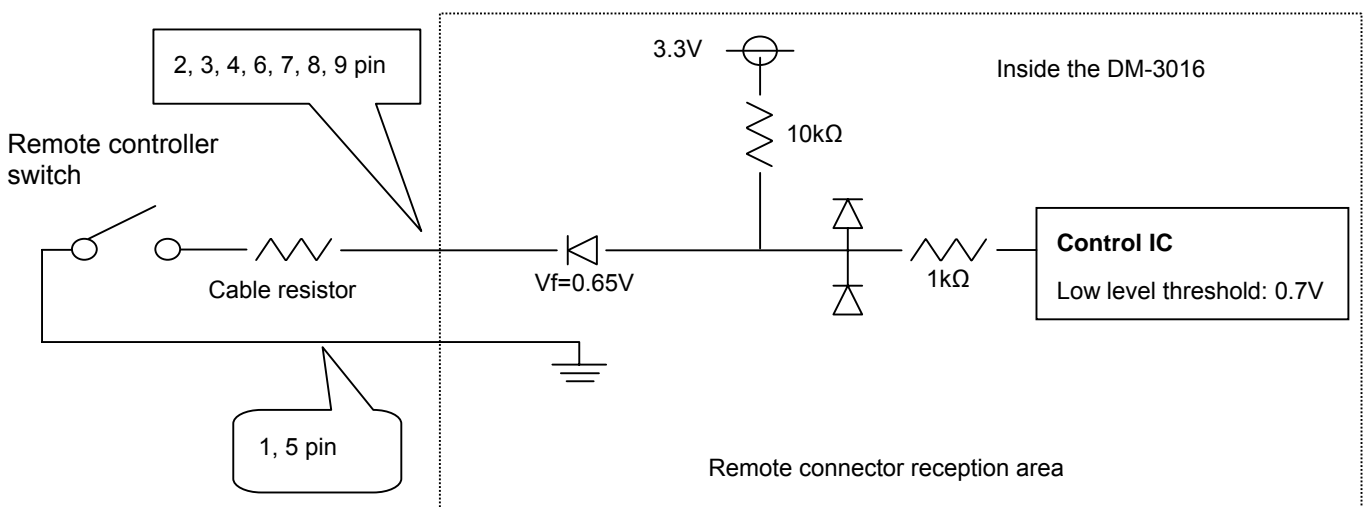

* Implement design in such a way that the cable resistor will have a resistance of 50Ω or less.



Do not plug or unplug the remote connector while power is supplied to the monitor.

3

OPERATION

3.1 Connection procedure

This section describes how to connect the DM-3016-F.

(1) Connecting the power supply

First check that the main unit's POWER switch is at the OFF position, and then connect one end of the AC cable (3-pin) to the power socket ((1) on the rear panel view) of the DM-3016-F. Connect the other end of the AC cable to a power outlet equipped with a protective ground terminal.

If a power outlet with a protective ground terminal is not available, be absolutely sure to ground the unit using its grounding terminal ((2) on the rear panel view).

(2) Connecting the input signals

When SDI signals are to be input, connect them to the SDI IN connector using a BNC coaxial cable. SDI IN serves as the input connector for the SDI signals, and MONITOR OUT as the output connector used for the simplified monitoring of the input SDI signals.

When HD-SDI signals are to be input, input serial signals which meet the BTA S-004B standard. Use a coaxial cable (5C-FB or its equivalent) which can handle frequencies in the 1.5 GHz band. When SD-SDI signals are to be input, input serial signals which meet the SMPTE259M (270 Mbps) standard.

When composite signals are to be input, connect them to the COMPOSITE connector using the BNC coaxial cable as above.

In the case of NTSC system composite signals, input signals which meet the SMPTE170M; in the case of PAL system composite signals, input signals which meet the ITU-R624-4 standard.

(3) Connecting the remote controller

Check that the monitor's POWER switch is at OFF, and then connect the remote controller to the remote connector ((3) on the rear panel view) of the DM-3016-F. Check the shape of the connector prior to use.

3.2 Usage

A protective film is adhered to the surface of the LCD panel. Peel it off before using the DM-3016-F. After checking the connections, turn on the power of the DM-3016-F by pressing the POWER switch on its front panel. The POWER LED lights, and images are displayed. If the POWER LED fails to light, check the connections again.

To conduct the simplified monitoring of the SDI input signals, use the MONITOR OUT connector. If no input signals are supplied, the image area appears all black, and  NoSignal is displayed in red on the screen.

* If the setting to display color bars is established when no input signals are supplied, the color bars will be displayed in the image area.

3.3 Concerning the screen displays





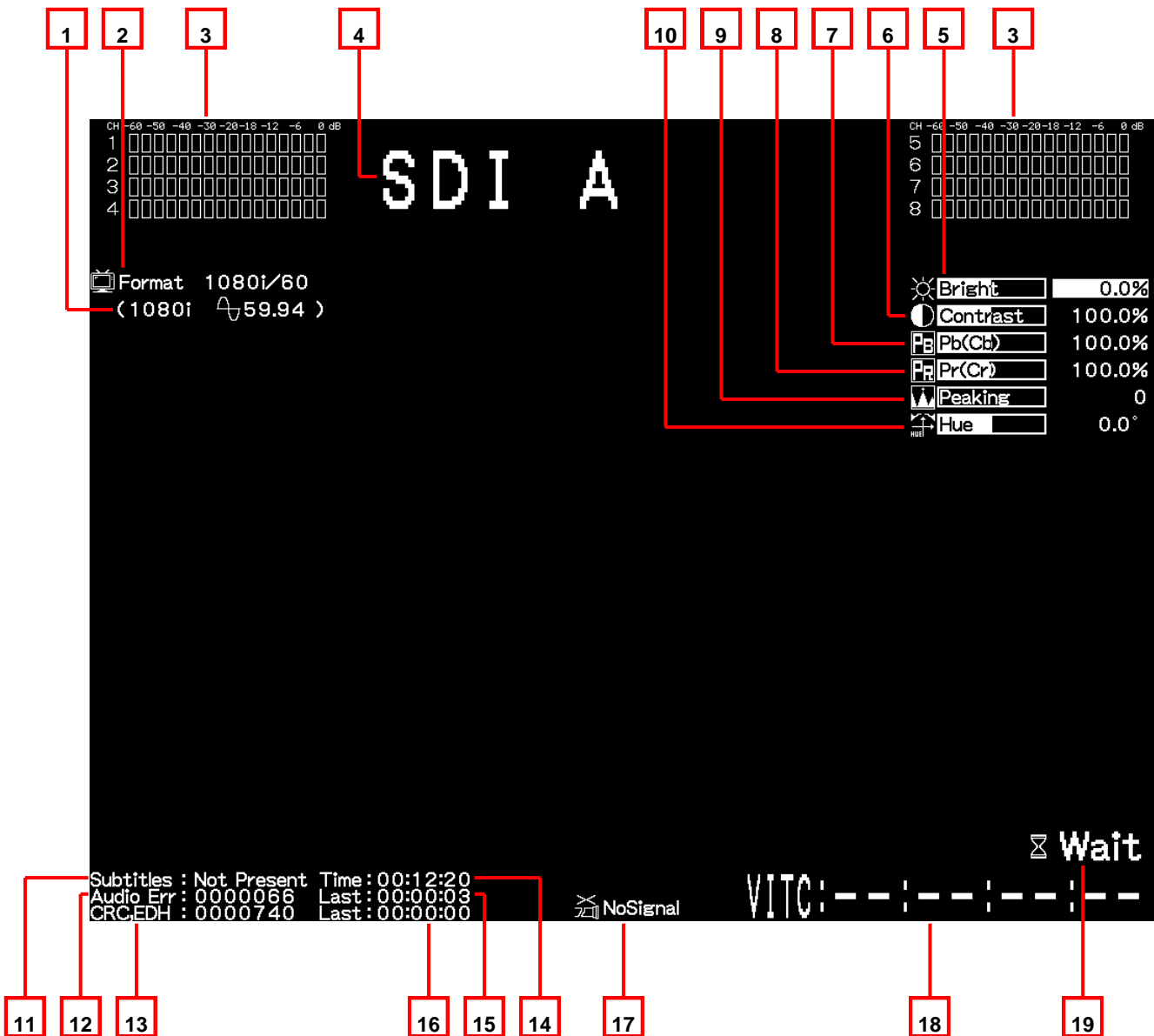









This section describes the displays appearing on the DM-3016-F screen.

3.3.1 Regular screen



NOTE

It is possible to set 1, 2, 3, 4, 11, 12, 13, 14, 15, 16 and 18 so that they will not be displayed. (Refer to sections 3.4.30 to 3.4.34.)

No.	Item	Description	
1	 (frequency)	The format and field (frame) frequency detected in the input signals are displayed here. If no signals are input (or with  NoSignal described below), ***** appears. (For details on the formats, refer to section 4.1.)	
2	 Format	The format setting is displayed here.	
3	ch *	The audio level meter is displayed here. (Refer to section 4.7.) (*1)	
4	(CH ID)	This indicates the name given to the input channel which has been selected.	
5	 Bright	This is where the brightness setting is displayed. (Refer to section 4.5.)	
6	 Contrast	This is where the contrast setting is displayed. (Refer to section 4.5.)	
7	 Pb(Cb)	When YPbPr has been selected as the Color Space setting	This is where the Pb (Cb) setting is displayed. (Refer to section 4.5.)
		When GBR has been selected as the Color Space setting	N/A appears, and the initial value temporarily serves as the setting. (Pb (Cb) cannot be set.)
8	 Pr(Cr)	When YPbPr has been selected as the Color Space setting	This is where the Pr (Cr) setting is displayed. (Refer to section 4.5.)
		When GBR has been selected as the Color Space setting	N/A appears, and the initial value temporarily serves as the setting. (Pr (Cr) cannot be set.)
9	 Peaking	This is where the peaking setting is displayed. (*3)	
10	 Hue	When YPbPr has been selected as the Color Space setting	This is where the hue setting is displayed.
		When GBR has been selected as the Color Space setting	N/A appears, and the initial value temporarily serves as the setting. (The hue cannot be set.)
11	Subtitles	Whether the subtitle data is present or not present is indicated here.	
12	Audio Err	Audio errors are checked here. The error count is displayed. When an error is detected,  Audio Err is displayed in red for 1 second.	
13	CRC,EDH	When HD-SDI signals are input, CRC errors are checked; when SD-SDI signals are input, EDH errors are checked; and, in either case, the error count is displayed. When an error is detected,  CRC,EDH is displayed in red for 1 second.	
14	Time	The time elapsed since the DM-3016-F was started up is displayed here.	
15	Last	The time elapsed since the last audio error occurred is displayed here.	
16	Last	The time elapsed since the last CRC or EDH error occurred is displayed here.	
17	 NoSignal	 NoSignal appears in red if the signals which have been input differ from the signals which have been set.	
18	VITC	The time code (VITC) is displayed here. (*2)	
19	 Wait	This indicates that data is being saved. Do not turn off the power while  Wait is displayed. If the power is turned off while the settings are being saved, all the user data saved in the monitor will be destroyed, and the initial settings will be established when the power is next turned on.	

*1: No sound is output when composite signals have been selected so the audio level meter does not work.

*2: The time codes are not displayed when composite signals have been selected.

*3 When you increase Peaking Level by using peaking, pixels may be skipped and disappeared as specification of the product.

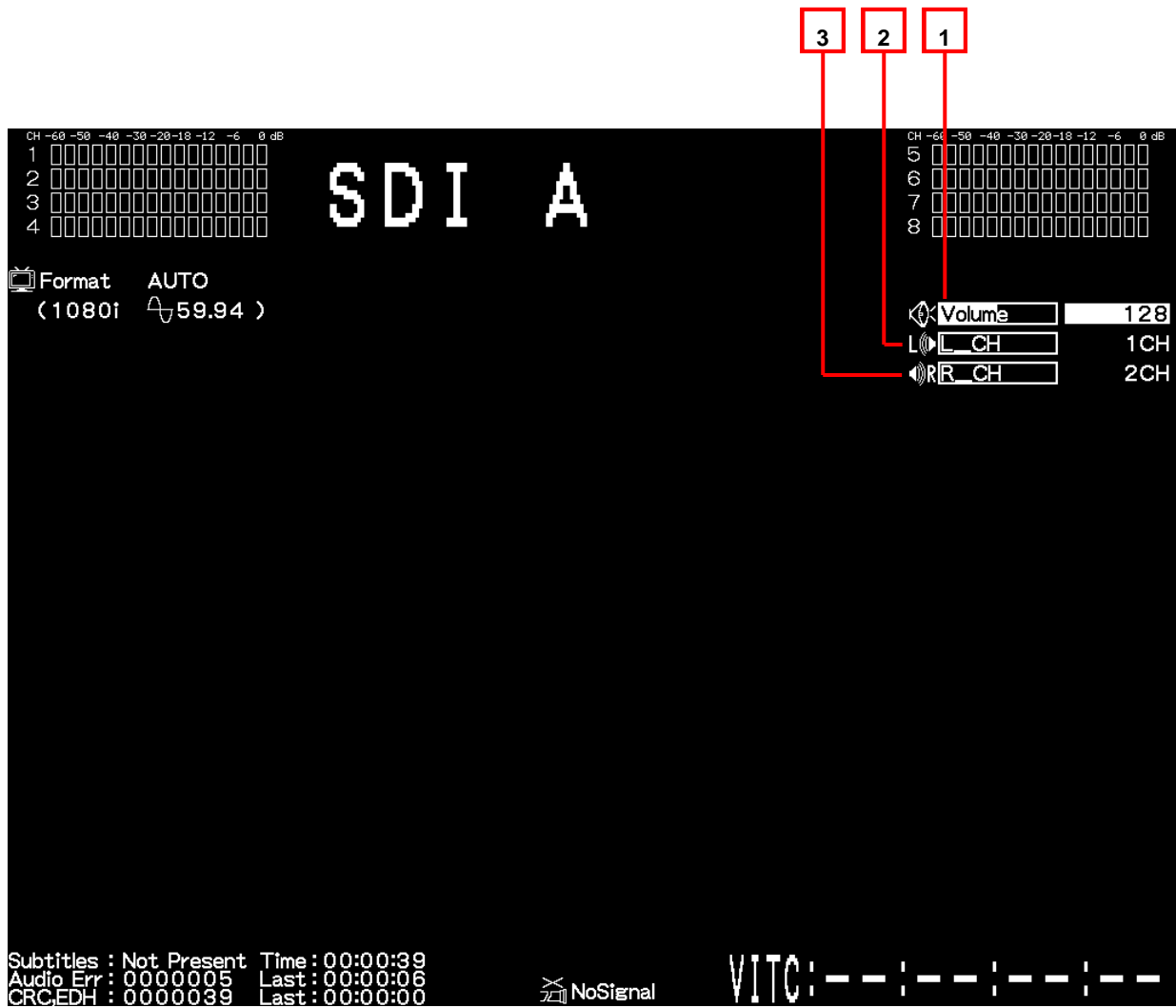

No.	Item	Description
1	Volume	This is where the setting for the volume which is to be output from the headphone jack is displayed.
2	L CH	This is where the audio channel output to the left is displayed.
3	R CH	This is where the audio channel output to the right is displayed.

3.3.2 Menu screen

When the MENU switch is pressed, the screen shown below appears, and the various functions indicated can be operated.

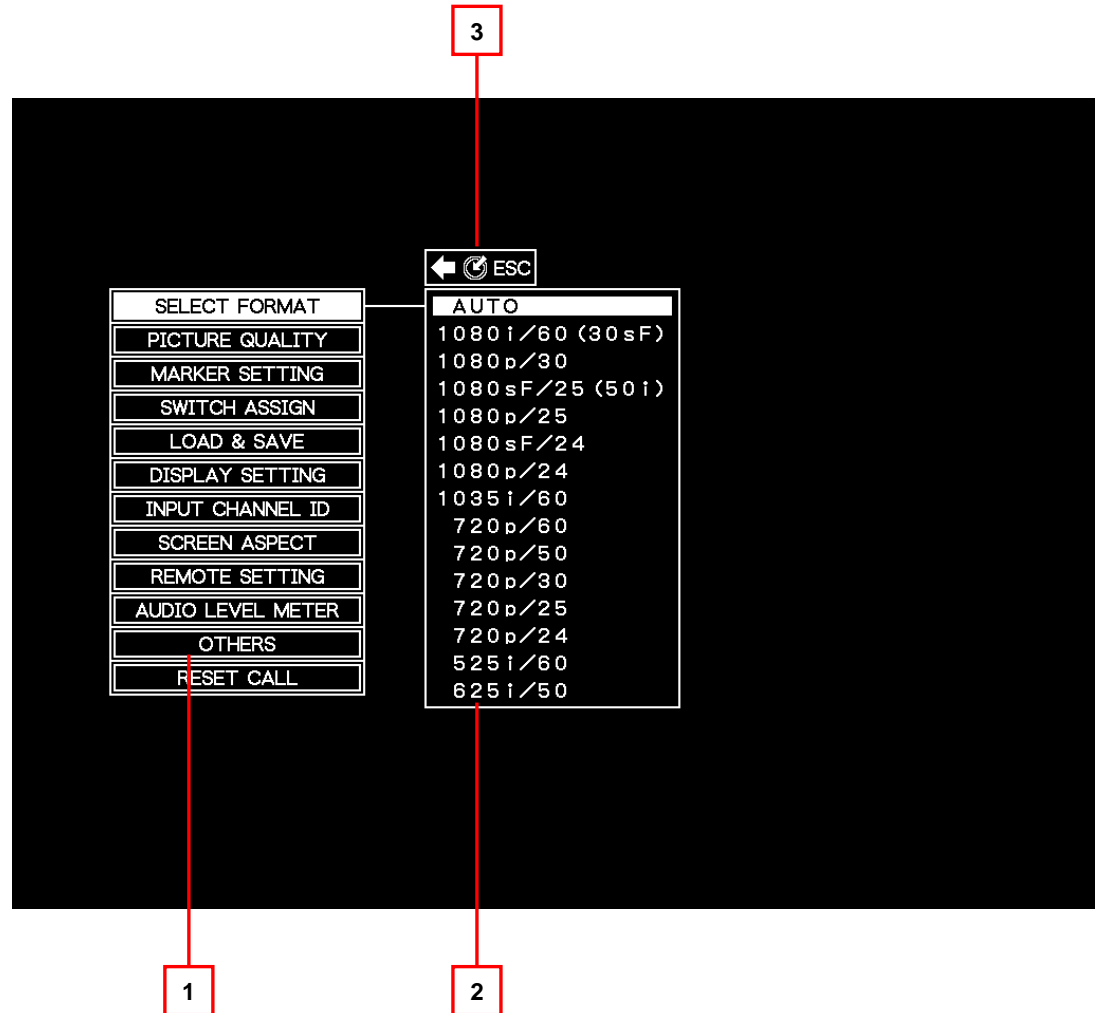

No.	Description
1	Menu on 1st hierarchical level
2	Menu on 2nd hierarchical level
3	This appears only when an operation has been performed using the adjustment dial. When the adjustment dial is now pressed, the menu on the next higher hierarchical level is restored.

* Some menu items have up to three hierarchical levels which are displayed.

3.3.3 Format selection screen

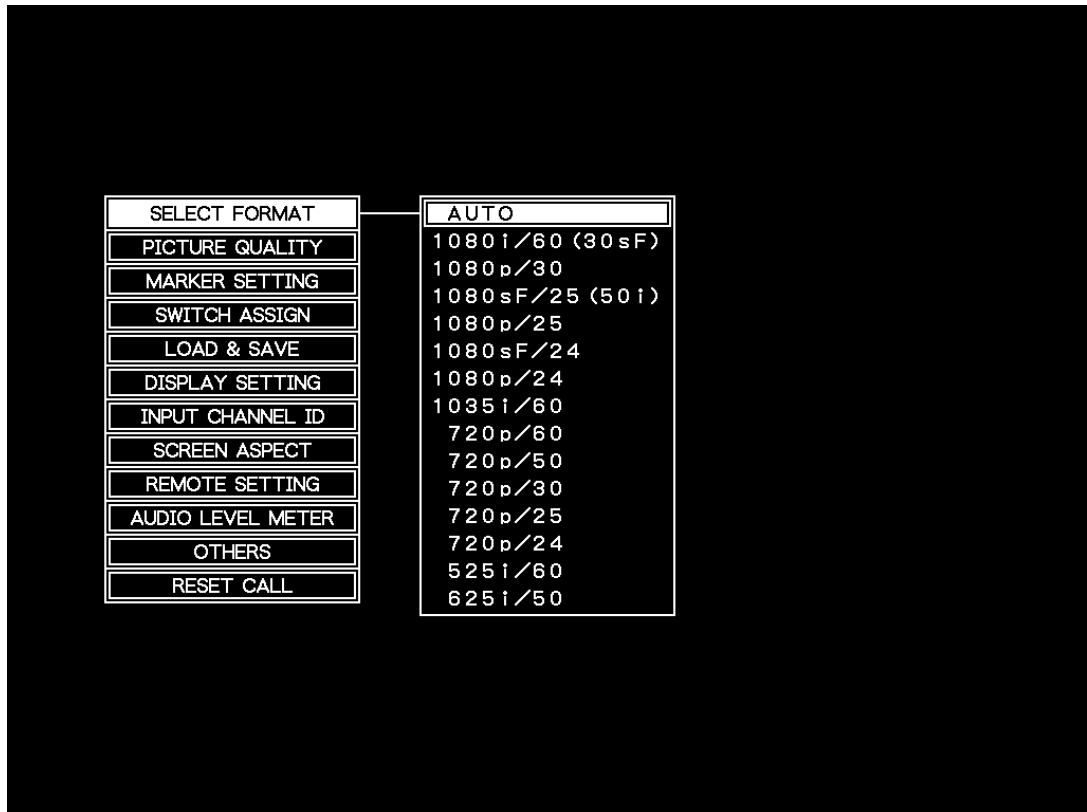

The operation which can be performed using this item is described below.

Item	Description
SELECT FORMAT	This is used to select the format. (Refer to section 3.4.2.)

3.3.4 LCD adjustment screen

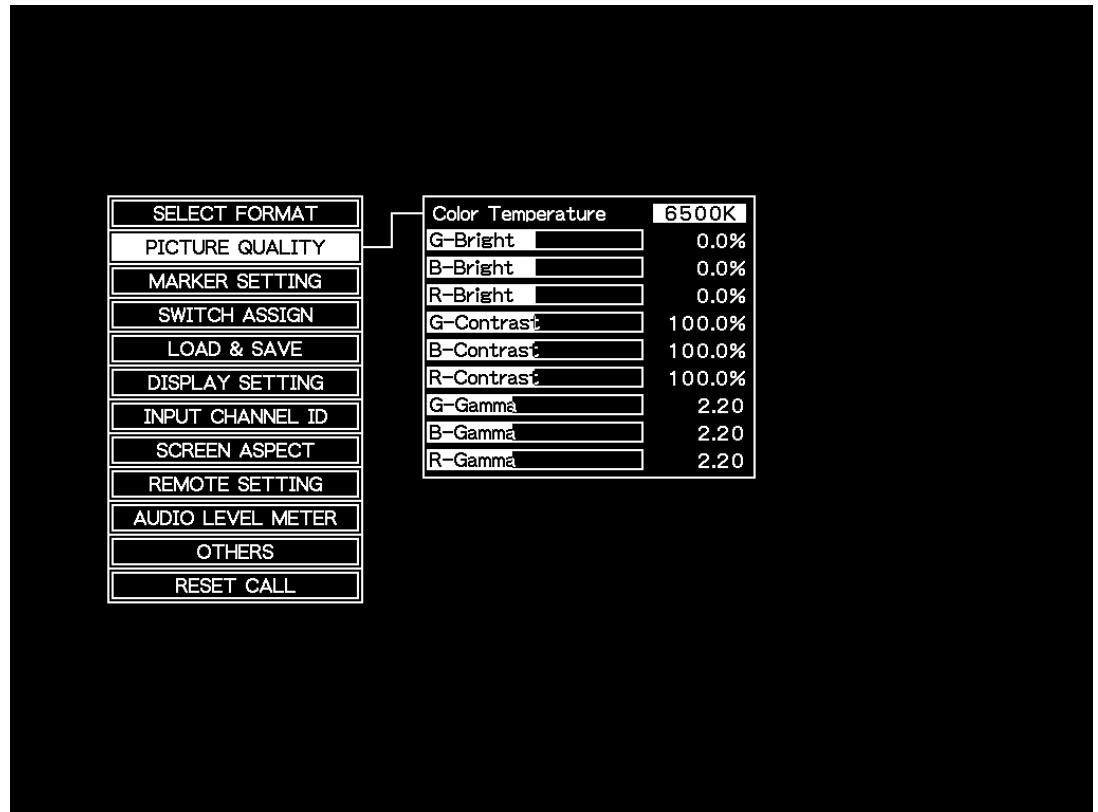

The operations which can be performed using the items on this screen are described below.

Item	Description
Color Temperature	This is used to set the LCD color temperature. (Refer to section 3.4.49.)
G-Bright	The G brightness setting is indicated here. (Refer to section 3.4.50.)
B-Bright	The B brightness setting is indicated here. (Refer to section 3.4.51.)
R-Bright	The R brightness setting is indicated here. (Refer to section 3.4.52.)
G-Contrast	The G contrast setting is indicated here. (Refer to section 3.4.53.)
B-Contrast	The B contrast setting is indicated here. (Refer to section 3.4.54.)
R-Contrast	The R contrast setting is indicated here. (Refer to section 3.4.55.)
G-Gamma	The G gamma setting is indicated here. (Refer to section 3.4.56.)
B-Gamma	The B gamma setting is indicated here. (Refer to section 3.4.57.)
R-Gamma	The R gamma setting is indicated here. (Refer to section 3.4.58.)

NOTE

The G brightness, B brightness, R brightness, G contrast, B contrast, R contrast, G gamma, B gamma and R gamma settings differ depending on the color temperature (5500K, 6500K or 9300K). The initial settings will be established when the power is next turned on.

3.3.5 Marker setting screen

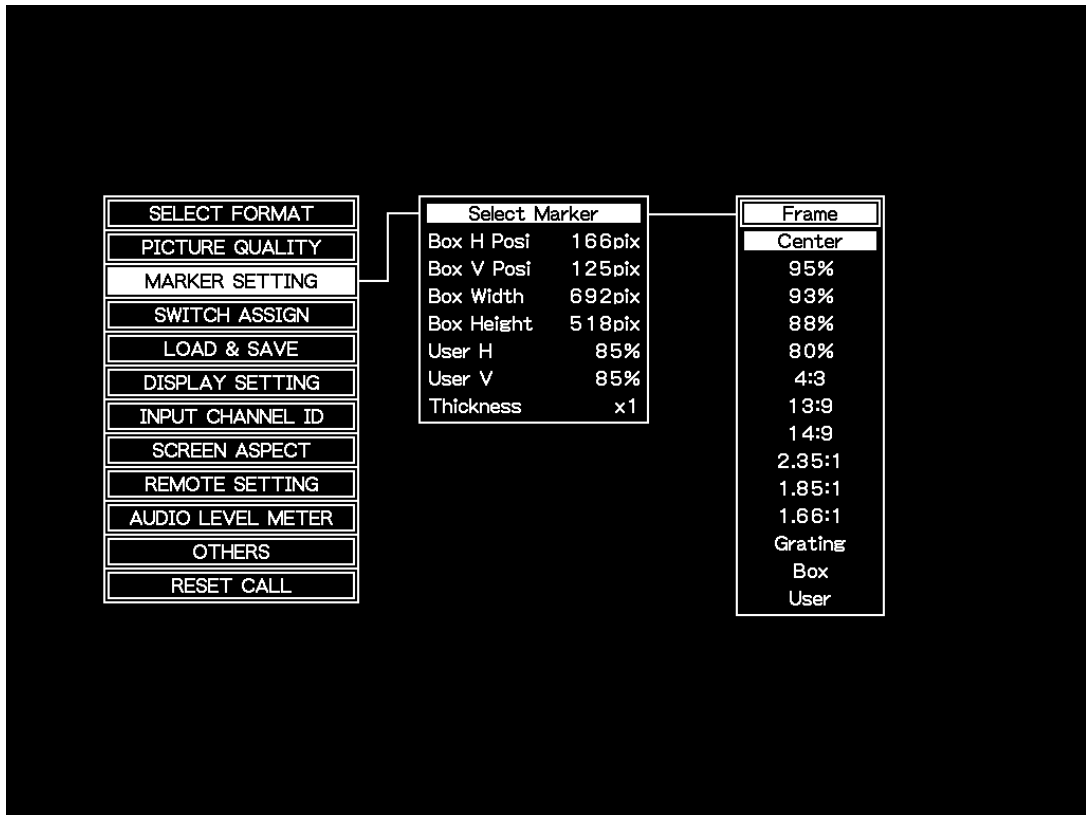

The operations which can be performed using the items on this screen are described below.

Item	Description
Select Marker	This is used to select the markers to be displayed. (Refer to section 3.4.8.)
Box H Posi	The position where the box marker is to be displayed is adjusted in the horizontal direction here. (Refer to section 3.4.9.)
Box V Posi	The position where the box marker is to be displayed is adjusted in the vertical direction here. (Refer to section 3.4.9.)
Box Width	The size of the box marker is adjusted in the horizontal direction here. (Refer to section 3.4.10.)
Box Height	The size of the box marker is adjusted in the vertical direction here. (Refer to section 3.4.10.)
User H	The position where the user marker is to be displayed is adjusted in the horizontal direction here. (Refer to section 3.4.11.)
User V	The position where the user marker is to be displayed is adjusted in the vertical direction here. (Refer to section 3.4.11.)
Thickness	This thickness of the marker is set here. (Refer to section 3.4.12.)

3.3.6 Front switch function allocation screen

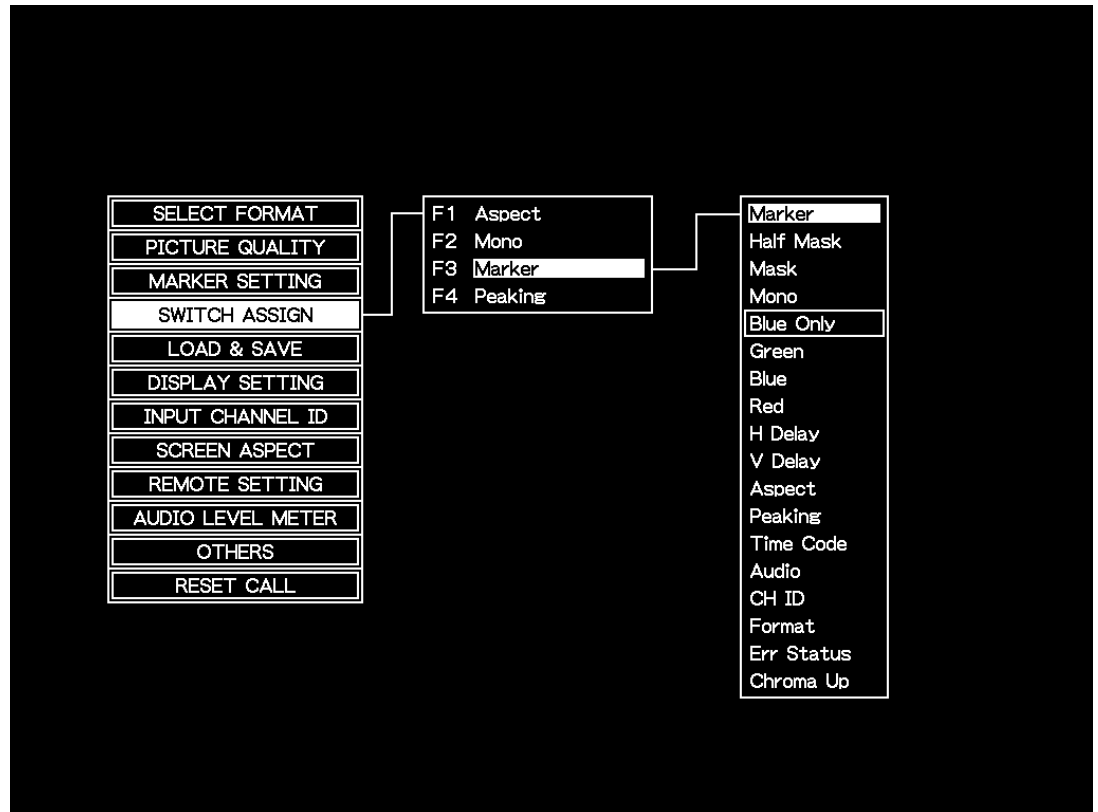

The operations which can be performed using the items on this screen are described below.

Item	Description
F1	This is used to select the function to be allocated to the F1 switch. (Refer to section 3.4.42.)
F2	This is used to select the function to be allocated to the F2 switch. (Refer to section 3.4.42.)
F3	This is used to select the function to be allocated to the F3 switch. (Refer to section 3.4.42.)
F4	This is used to select the function to be allocated to the F4 switch. (Refer to section 3.4.42.)

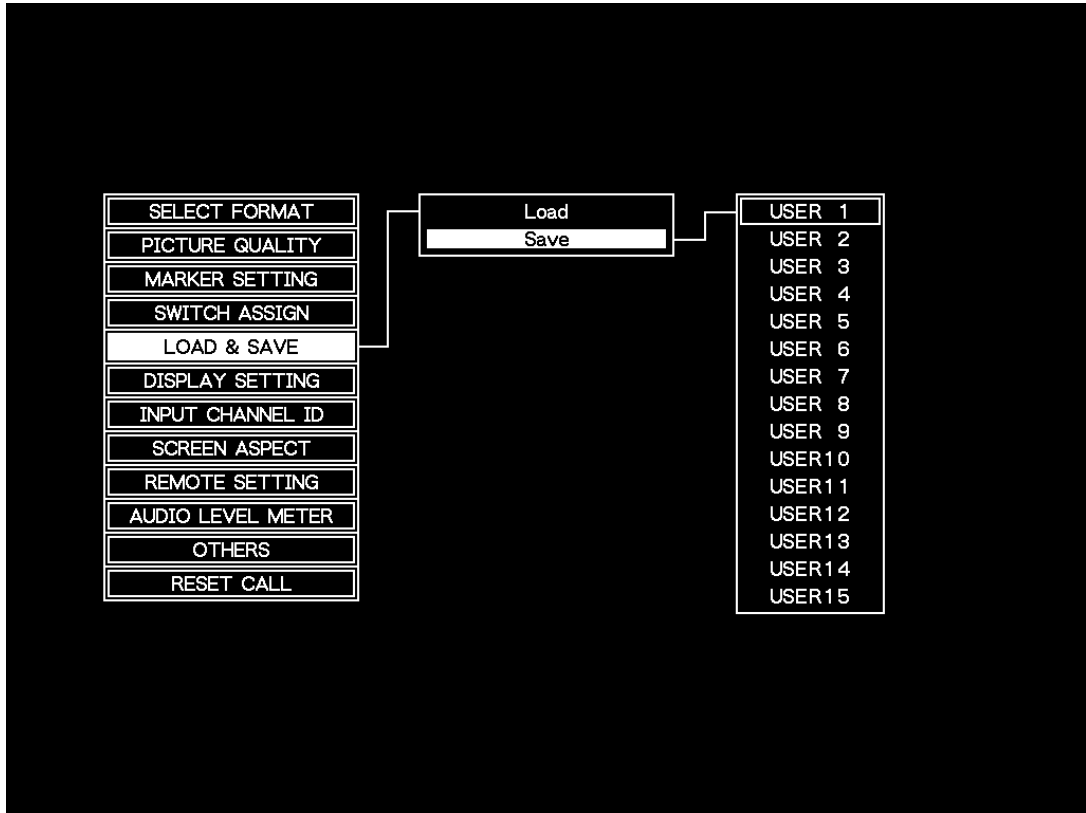

3.3.7 User settings save and load screen



The operations which can be performed using the items on this screen are described below.

Item	Description
Load	This is used to load the settings which have been saved in USER1 to USER15 . (Refer to section 3.4.47.)
Save	This is used to save the settings in USER1 to USER15 . (Refer to section 3.4.47.)

NOTE

 Wait appears on the screen while the settings are being loaded or saved. Under no circumstances must the power be turned off while  Wait is displayed. If the power is turned off while the settings are being saved, all the user data saved in the monitor will be destroyed, and the initial settings will be established when the power is next turned on.

3.3.8 Display information selection screen

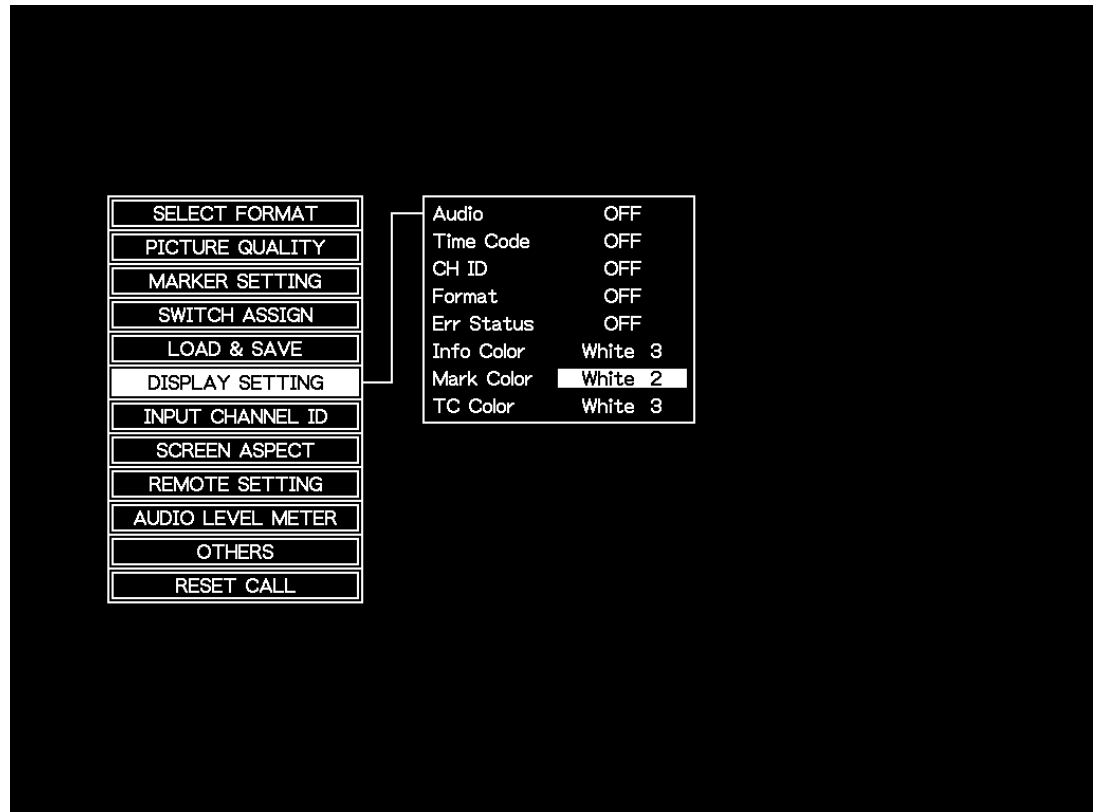

The operations which can be performed using the items on this screen are described below.

Item	Description
Audio	This is where the audio level meter display is set to ON or OFF. (*1) (Refer to section 3.4.30.)
Time Code	This is where the time code display is set to ON or OFF. (Refer to section 3.4.31.)
CH ID	This is where the input channel ID (character) display is set to ON or OFF. (Refer to section 3.4.32.)
Format	This is where the input signal format display is set to ON or OFF. (Refer to section 3.4.33.) When it is ON, the format is displayed for only 3 seconds after the format has been changed.
Err Status	This is where the subtitle data, audio error count, CRC/EDH error count, Time and Last display are set to ON or OFF. (Refer to section 3.4.34.)
Info Color	This is where the display color of the displayed information except for the markers and time code is changed. (Refer to section 3.4.63.)
Mark Color	This is where the display color of the markers is changed. (Refer to section 3.4.61.)
TC Color	This is where the display color of the time code is changed. (Refer to section 3.4.62.)

NOTE

(*1) This is the same function as **Audio** on the 3.3.12 Audio level meter display setting screen. Whether it was set on the display information selection screen or on the audio level meter display setting screen, the same setting will be used for **Audio**.

3.3.9 Input signal name setting screen

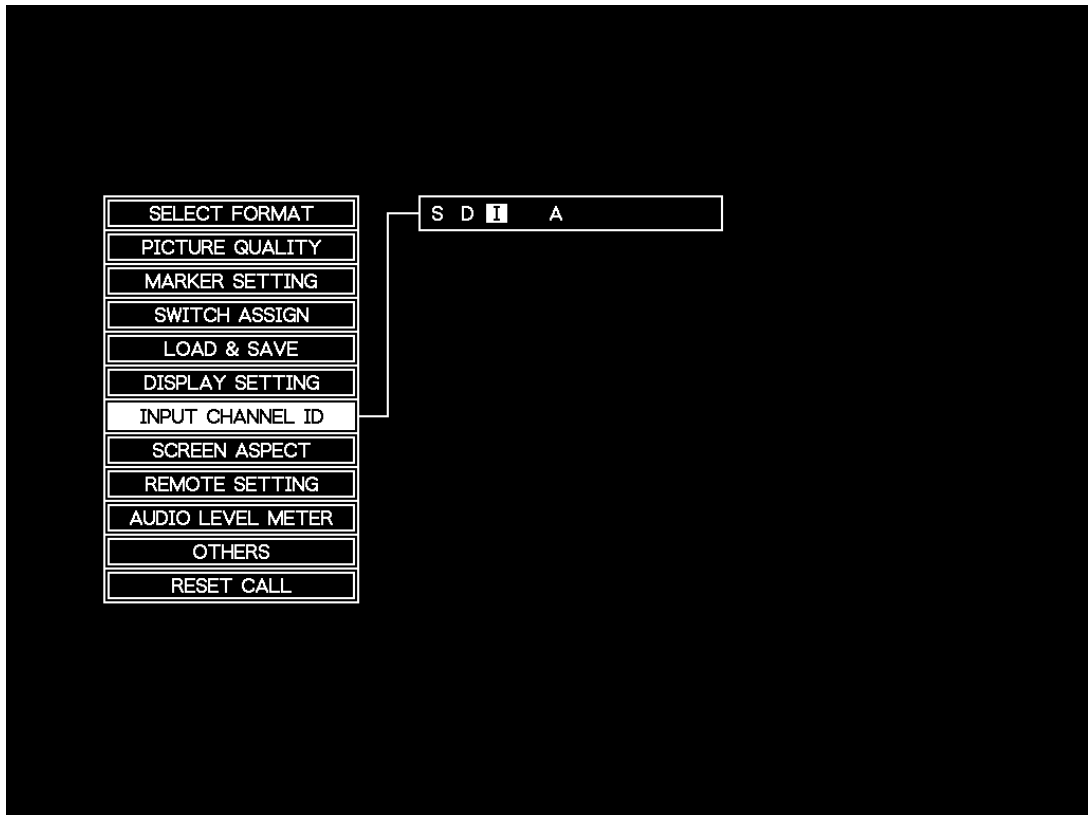

The operation which can be performed using the item on this screen is described below.

Item	Description
INPUT CHANNEL ID	This is used to change the names of the input signals. (Refer to section 3.4.44.)

NOTE

Upper-case and lower-case letters, numerals and basic symbols listed below can be used for the names, and up to 10 characters can be displayed.

List of usable characters

	!	"	#	\$	%	&		()	*	+	,	-	.	/
0	1	2	3	4	5	6	7	8	9	:	;	<	=	>	?
@	A	B	C	D	E	F	G	H	I	J	K	L	M	N	O
P	Q	R	S	T	U	V	W	X	Y	Z	[\]	^	_
	a	b	c	d	e	f	g	h	i	j	k	l	m	n	o
p	q	r	s	t	u	v	w	x	y	z	{		}	~	

3.3.10 Aspect ratio selection screen

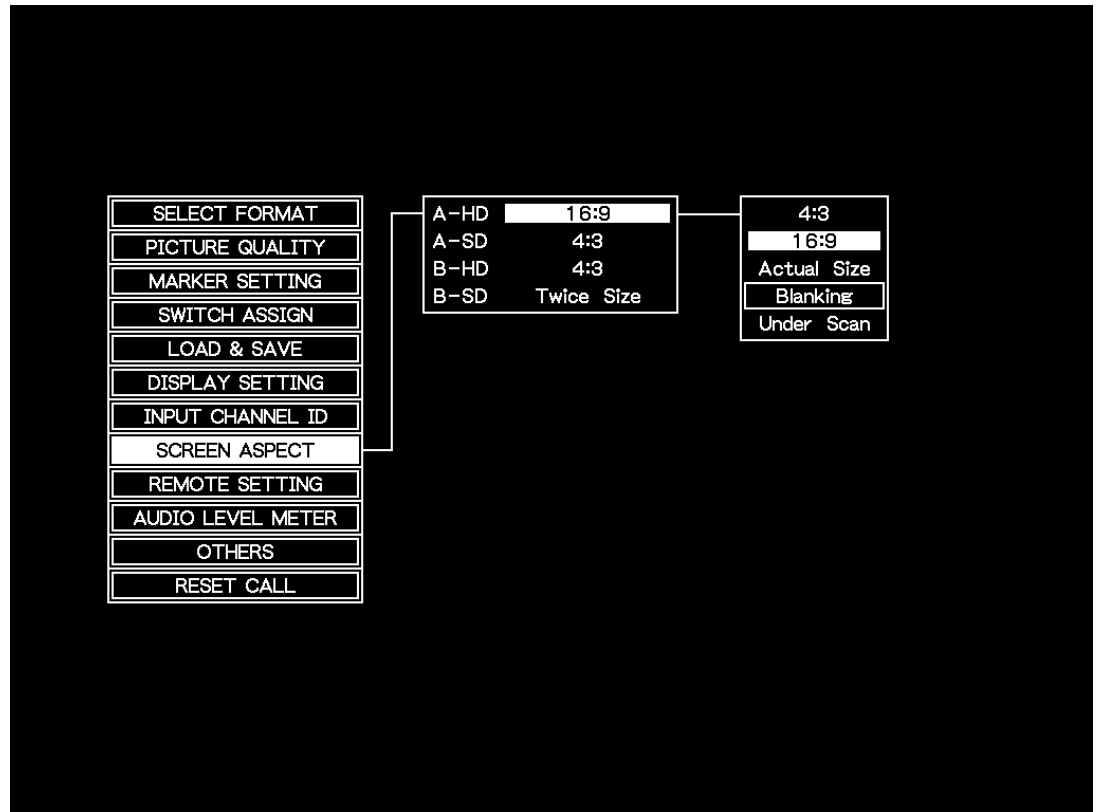

The operations which can be performed using the items on this screen are described below.

Item	Description
A - HD	The aspect ratio when HD signals are input is selected here. (Refer to section 3.4.4.)
A - SD	The aspect ratio when SD signals are input is selected here. (Refer to section 3.4.4.)
B - HD	The aspect ratio when HD signals are input is selected here. (Refer to section 3.4.4.)
B - SD	The aspect ratio when BD signals are input is selected here. (Refer to section 3.4.4.)

NOTE

The aspect ratios which can be selected are listed below.

Format	Aspect ratios which can be selected
A-HD/B-HD	H_Full, V_Full, Actual Size, Blanking, Under Scan
A-SD/B-SD	H_Full, V_Full, 16:9, Blanking, Under Scan

3.3.11 Remote controller setting screen

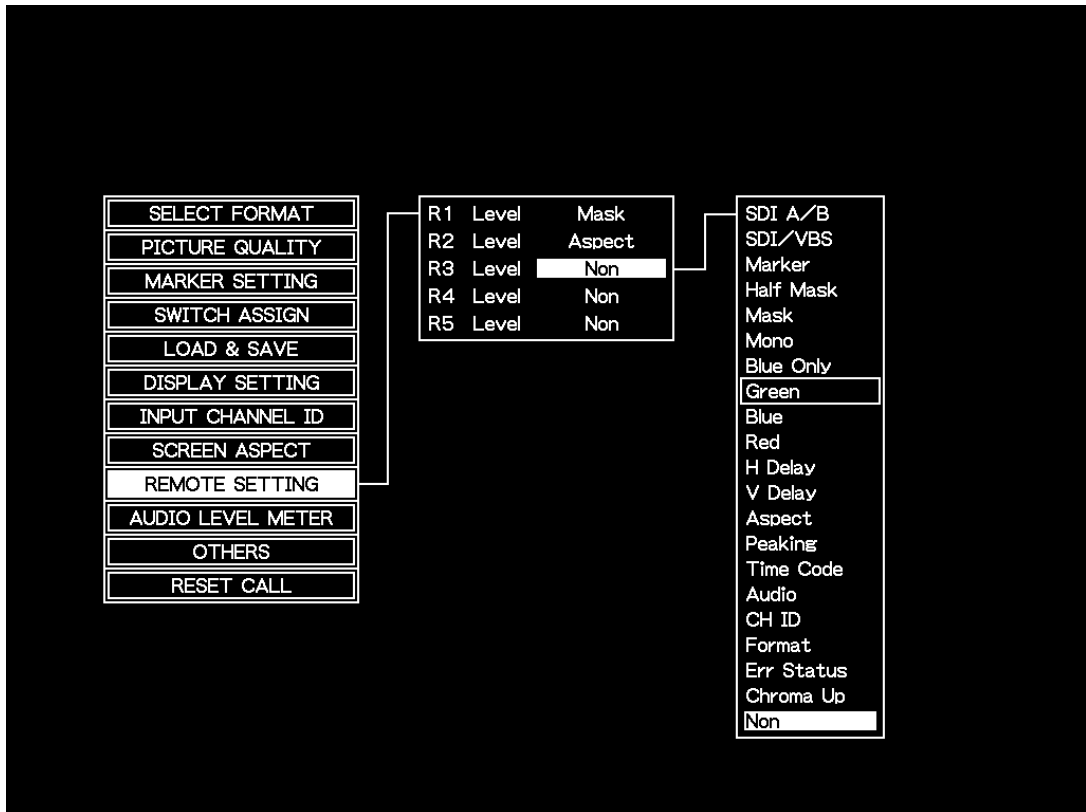

The operations which can be performed using the items on this screen are described below.

Item	Description
R1	This is where the operation method of remote controller 1 and the supported items are set. (Refer to section 3.4.43.)
R2	This is where the operation method of remote controller 2 and the supported items are set. (Refer to section 3.4.43.)
R3	This is where the operation method of remote controller 3 and the supported items are set. (Refer to section 3.4.43.)
R4	This is where the operation method of remote controller 4 and the supported items are set. (Refer to section 3.4.43.)
R5	This is where the operation method of remote controller 5 and the supported items are set. (Refer to section 3.4.43.)

3.3.12 Audio level meter display setting screen

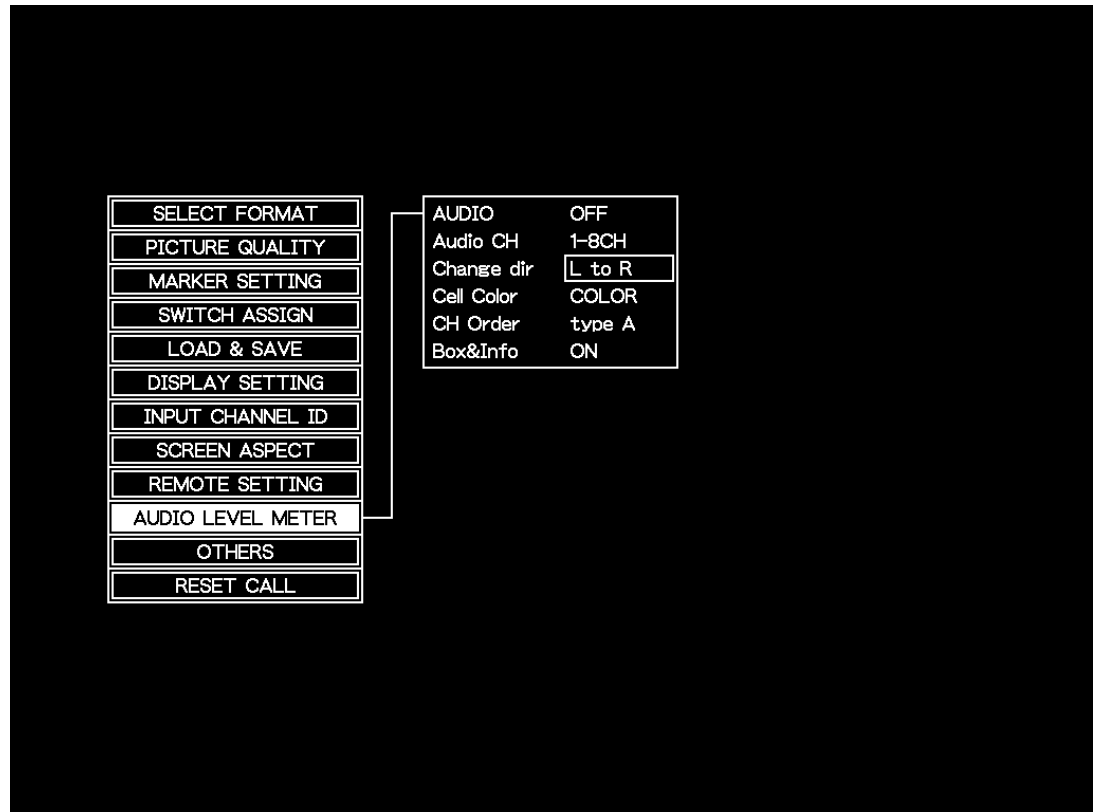

The operations which can be performed using the items on this screen are described below.

Item	Description
AUDIO	This is where the audio level meter display is set to ON or OFF. (*1) (Refer to section 3.4.30.)
Audio CH	This is where the channels to be displayed by the audio level meter are selected. (*2) (Refer to section 3.4.25.)
Change dir	This is where the audio meter level display format is selected. (Refer to section 3.4.26.)
Cell Color	This is where the color display or monochrome display is selected for the audio level meter. (Refer to section 3.4.27.)
CH Order	This is where the channel layout of the audio level meter is selected. (Refer to section 3.4.28.)
Box&Info	This is where the audio level meter frame and information are set to ON or OFF. (Refer to section 3.4.29.)

NOTE

- (*1) This is the same function as **Audio** on the 3.3.8 Display information selection screen. Whether it was set on the display information selection screen or on the audio level meter display setting screen, the same setting will be used for **Audio**.
- (*2) This is the same function as **Audio CH** on the other functions setting screen in section 3.3.13. For this reason, whether it was set on the audio level meter display setting screen or other functions setting screen, the same setting will be used for **Audio CH**.

3.3.13 Other functions setting screen

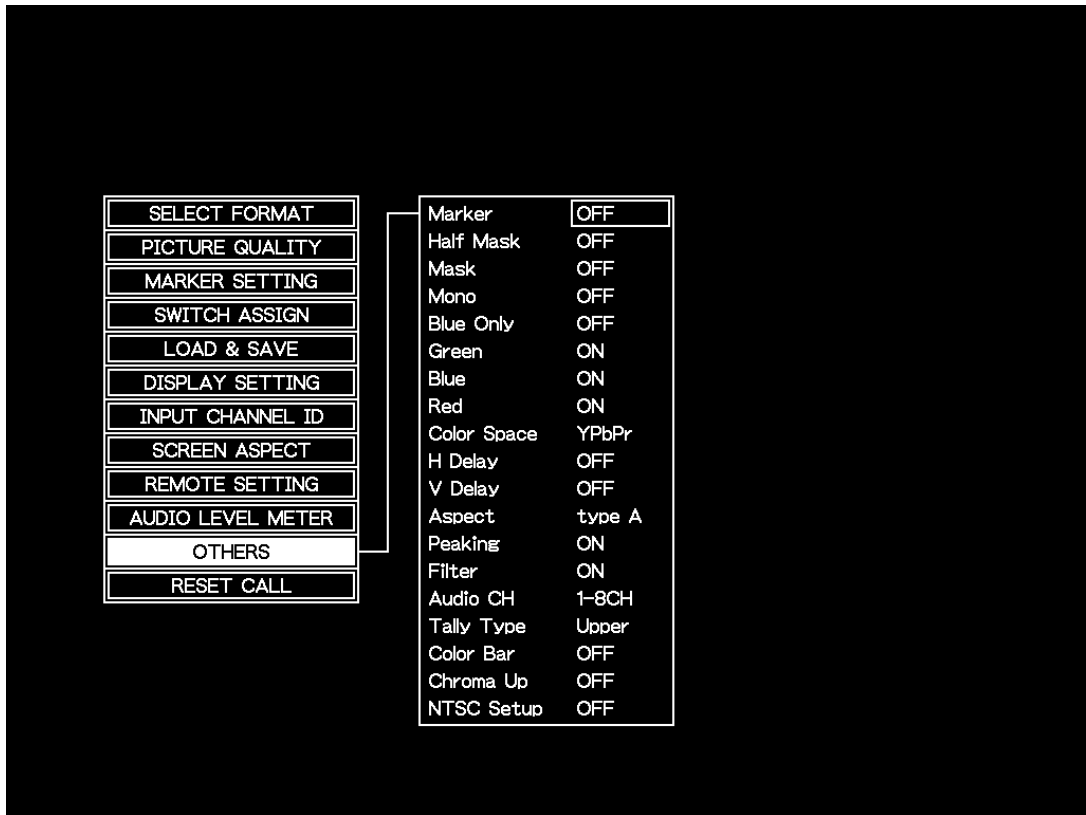

The operations which can be performed using the items on this screen are described below.

Item	Description
Marker	This is where the markers are set to ON or OFF. (Refer to section 3.4.7.)
Half Mask	This is where the half mask is set to ON or OFF. (Refer to section 3.4.35.)
Mask	This is where the mask is set to ON or OFF. (Refer to section 3.4.35.)
Mono	This is where the monochrome images are set to ON or OFF. (Refer to section 3.4.5.)
Blue Only	This is where blue only is set to ON or OFF. (Refer to section 3.4.6.)
Green	This is where the green component of the images is set to ON or OFF. (Refer to section 3.4.37.)
Blue	This is where the blue component of the images is set to ON or OFF. (Refer to section 3.4.38.)
Red	This is where the red component of the images is set to ON or OFF. (Refer to section 3.4.39.)
Color Space	This is where YPbPr or GBR is selected. (Refer to section 3.4.36.)
H Delay	This is where H delay is set to ON or OFF. (Refer to section 3.4.40.)
V Delay	This is where V delay is set to ON or OFF. (Refer to section 3.4.41.)
Aspect	This is where the aspect ratio is selected. (Refer to section 3.4.3.)
Peaking	This is where peaking is set to ON or OFF. (Refer to section 3.4.19.)
Filter	This is where the filter is set to ON or OFF. (Refer to section 3.4.22.)
Audio CH	This is where the channels to be displayed by the audio level meter are selected. (*1) (Refer to section 3.4.25.)

Tally Type	This is where the tally display method is selected. (Refer to section 3.4.24.)
Color Bar	This is where it is selected whether the color bar images are to be displayed when no signals are input is selected. (Refer to section 3.4.45.)
Chroma Up	This is where the function for multiplying the chroma signal value by 3 is set to ON or OFF. (Refer to section 3.4.18.)
NTSC Setup	This is where the NTSC pedestal level is selected. (Refer to section 3.4.46.)

NOTE

(*1) This is the same function as Audio CH on the other functions setting screen in section 3.3.13. For this reason, no matter whether it was set on the audio level meter display setting screen or other functions setting screen, the same setting will be used for Audio CH.

CAUTION

When "Peaking" is active, it stops interpolation process and shows image as simple skipping. In this case thin line may not shown and Hatched line is shown with jaggy.

3.3.14 Reset screen

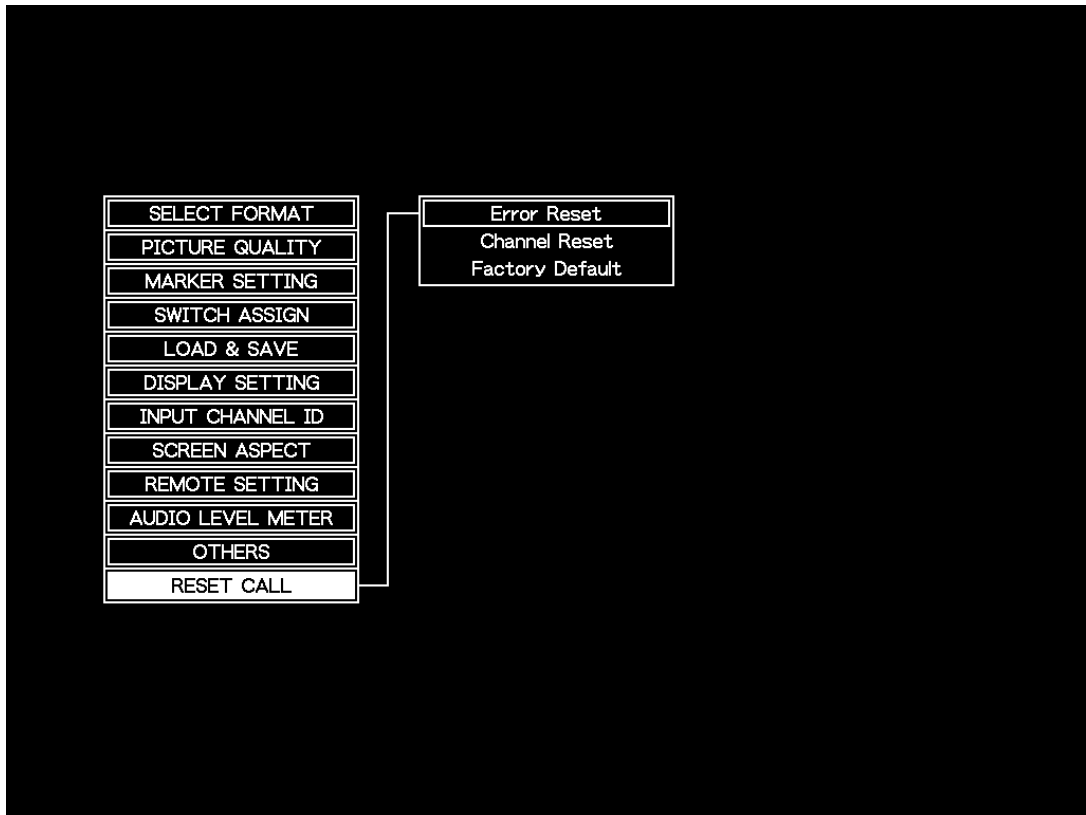

The operations which can be performed using the items on this screen are described below.

Item	Description
Error Reset	This is where the error count and elapsed time are set to zero. (Refer to section 3.4.48.)
Channel Reset	This is where the settings for each channel are returned to the initial values. (Refer to section 3.4.48.)
Factory Default	This is where the factory settings are loaded. (Refer to section 3.4.48.)

3.3.15 Infrared remote control ID setting screen

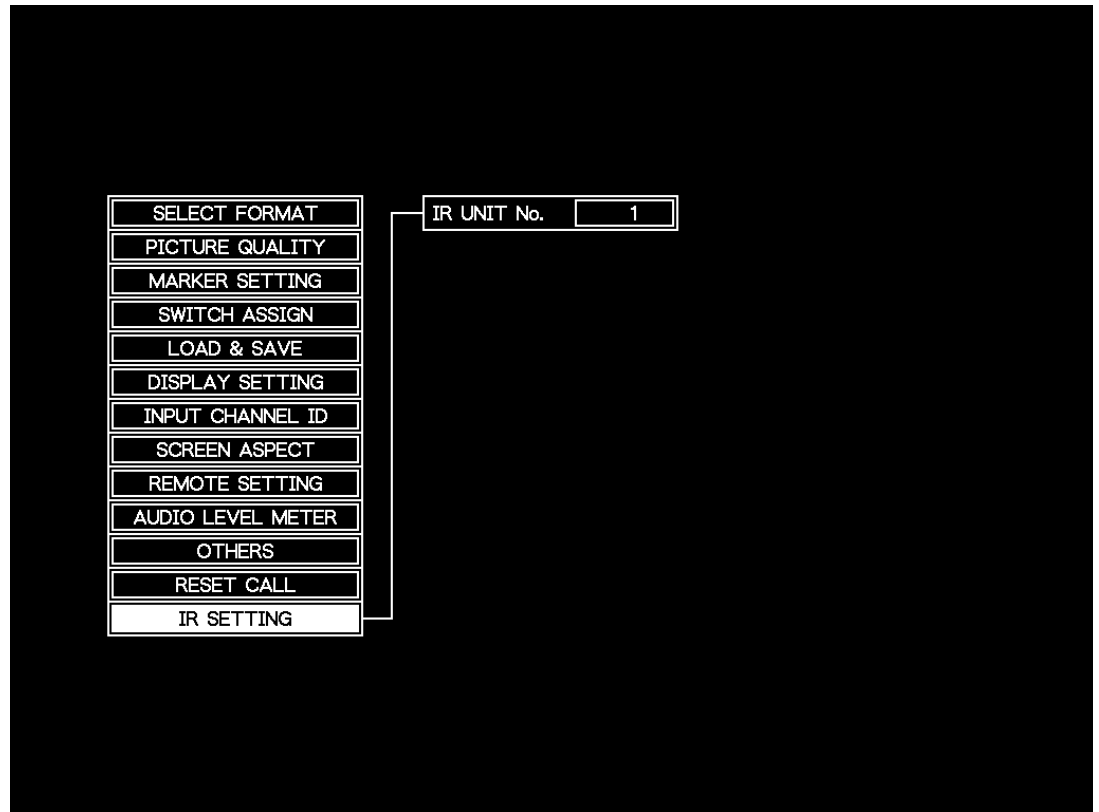

The operation which can be performed using the item on this screen is described below.

Item	Description
IR UNIT No.	This is used to set an ID (from No.1 to 99) for the DM-3016-F main unit.

*If the ID which has been set by the RB-1666 infrared remote controller (optional accessory) and the ID number set for the DM-3016-F main unit match, the DM-3016-F will respond to operations performed from the RB-1666.

* For further details, refer to the operating instructions of the RB-1666 infrared remote controller.

3.4 Description of functions and operating procedures



If an item is accompanied by this mark, it means that its operation can be controlled by the remote controller. For further details on these operations, refer to section 3.4.43.



If an item is accompanied by this mark, it means that its operation can be controlled by one of the function switches, F1 to F4. For further details on these operations, refer to section 3.4.42.

3.4.1 Selecting the input signals



When the front panel switches are used

1. Press the SDI A switch, the SDI B switch or ANALOG switch.

When the remote controller is used

1. Press the switch to which the SDI A/B or SDI/VBS function has been allocated.

NOTE

- (1) The SDI A switch is used for displaying the signals which have been input to the monitor's SDI IN channel A connector, the SDI B switch for displaying the signals which have been input to the SDI IN channel B connector, and the ANALOG switch for displaying the signals which have been input to the Y IN, Pb IN, Pr IN or COMPOSITE connector. Each time ANALOG switch is pressed COMPOSITE display and COMPONENT display is switched. Setting of when display is shown at the last was saved in ANALOG switch.
- (2) When ANALOG is selected, SDI A/B will be switch of MONITOR OUT.

3.4.2 Selecting the format

1. Press the MENU switch.
2. Turn the adjustment dial to select **SELECT FORMAT**, and press the ENT switch.
3. Turn the adjustment dial to select the format, and press the ENT switch to enter the format.

NOTE

When AUTO is selected as the format setting, the input signals are identified and automatically tracked. If any other setting is selected, processing is based on the timing system of the format designated. However, if composite signals are displayed, only three formats can be selected: AUTO, 525i/60 and 625i/50.

<Format types>

AUTO, 1080i/60(30sF), 1080p/30, 1080sF/25(50i), 1080p/25, 1080sF/24, 1080p/24, 1035i/60, 720p/60, 720p/50, 720p/30, 720p/25, 720p/24, 525i/60, 625i/50

3.4.3 Selecting the aspect ratio



1. Press the MENU switch.
2. Turn the adjustment dial to select **OTHERS**, and press the ENT switch.
3. Turn the adjustment dial to select **Aspect**, press the ENT switch, and select type A or type B.

NOTE

Refer to the next section for the method used to set the aspect ratio (type A/type B) to be selected.

3.4.4 Setting the aspect ratio

1. Press the MENU switch.
2. Turn the adjustment dial to select **SCREEN ASPECT**, and press the ENT switch.
3. Turn the adjustment dial to select the aspect ratio to be changed, and press the ENT switch.
4. Turn the adjustment dial to select the aspect ratio which has been changed, and press the ENT switch.

NOTE

When HD signals are input respectively for type A or type B, select the display method applying when SD signals are input. For details on the aspect ratios which can be selected, refer to section 4.6.

3.4.5 Selecting the monochrome display or color display



1. Press the MENU switch.
2. Turn the adjustment dial to select **OTHERS**, and press the ENT switch.
3. Turn the adjustment dial to select **Mono**, and press the ENT switch to switch the display from monochrome or color or vice versa.

CAUTION

When blue only, G, B or R is set from ON to OFF or vice versa while the monochrome display is ON, the monochrome display will be set to OFF. When the monochrome display is set from ON to OFF or vice versa, G, B and R will all be set to ON.

3.4.6 Selecting the blue only or color display



1. Press the MENU switch.
2. Turn the adjustment dial to select **OTHERS**, and press the ENT switch.
3. Turn the adjustment dial to select **Blue Only**, and press the ENT switch to switch the display from blue only to color or vice versa.



When monochrome, G, B or R is set from ON to OFF or vice versa while blue only is ON, blue only will be set to OFF.
When blue only is set from OFF to ON, G, B and R will all be set to ON.

3.4.7 Displaying the markers



1. Press the MENU switch.
2. Turn the adjustment dial to select **OTHERS**, and press the ENT switch.
3. Turn the adjustment dial to select **Marker**, and press the ENT switch to set the markers to ON or OFF.

3.4.8 Selecting the markers to be displayed

1. Press the MENU switch.
2. Turn the adjustment dial to select **MARKER SETTING**, and press the ENT switch.
3. Turn the adjustment dial to select **Select Marker**, and press the ENT switch.
4. Turn the adjustment dial to select the markers to be displayed, and press the ENT switch to enter the marker selection.

NOTE

Markers can be selected to be superimposed onto each other.
The names of the currently selected markers are highlighted.

<Types of markers>

FRAME, CENTER, 95%, 93%, 88%, 80%, 4:3, 13:9, 14:9, 2.35:1, 1.85:1, 1.66:1, Grating, Box, User

The table below shows the correlation between the selected format, aspect ratio and markers which are displayed.

ASPECT RATIO MARKER NAME	1080, 720 format					1035 format					SD				
	(1)	(2)	(3)	(4)	(5)	(1)	(2)	(3)	(4)	(5)	(1)	(2)	(6)	(4)	(5)
Frame	×	○	×	○	○	×	○	×	○	○	×	○	×	○	○
Center	○	○	○	○	○	○	○	○	○	○	○	○	○	○	○
95%	○	○	×	○	○	○	○	×	○	○	○	○	×	○	○
93%	○	○	×	○	○	○	○	×	○	○	○	○	×	○	○
88%	○	○	×	○	○	○	○	×	○	○	○	○	×	○	○
80%	○	○	×	○	○	○	○	×	○	○	○	○	×	○	○
4:3	×	○	×	○	○	×	○	×	○	○	×	○	×	×	×
13:9	×	○	×	○	○	×	○	×	○	○	○	○	×	×	×
14:9	×	○	×	○	○	×	○	×	○	○	○	○	×	×	×
2.35:1	×	○	×	○	×	×	○	×	○	○	○	○	×	○	○
1.85:1	×	○	×	○	○	×	×	×	○	○	○	○	×	○	○
1.66:1	×	○	×	○	○	×	○	×	×	×	○	○	×	○	○
Grating	○	○	○	○	○	○	○	○	○	○	○	○	○	○	○
Box	○	○	○	○	○	○	○	○	○	○	○	○	○	○	○
User	○	○	○	○	○	○	○	○	○	○	○	○	○	○	○

*: Aspect ratios: (1) 4:3, (2) 16:9, (3) Actual Size, (4) Blanking, (5) Under Scan, (6) Twice Size

CAUTION

If **AUTO** is selected as the format and no signals are input, the markers for the 1080 format will be displayed.

3.4.9 Adjusting the box marker display position

1. Press the MENU switch.
2. Turn the adjustment dial to select **MARKER SETTING**, and press the ENT switch.
3. Turn the adjustment dial to select **Box H Posi** or **Box V Posi**, and press the ENT switch.
4. Turn the adjustment dial to adjust the box marker display position, and press the ENT switch to enter the position.

**CAUTION**

To display the box marker, MARKER must be set to ON, and BOX must be selected using **Select Marker**.

3.4.10 Adjusting the box marker size

1. Press the MENU switch.
2. Turn the adjustment dial to select **MARKER SETTING**, and press the ENT switch.
3. Turn the adjustment dial to select **Box Width** or **Box Height**, and press the ENT switch.
4. Turn the adjustment dial to adjust the box marker size, and press the ENT switch to enter the size.

**CAUTION**

To display the box marker, MARKER must be set to ON, and BOX must be selected using **Select Marker**.

3.4.11 Adjusting the user marker display position

1. Press the MENU switch.
2. Turn the adjustment dial to select **MARKER SETTING**, and press the ENT switch.
3. Turn the adjustment dial to select **User H** or **User V**, and press the ENT switch.
4. Turn the adjustment dial to adjust the user marker display position, and press the ENT switch to enter the position.

NOTE

When 16:9, Blanking or Under Scan serves as the aspect ratio setting, the percentage will be that of the image area: when 4:3, Actual Size or Twice Size serves as the setting, it will be that of the LCD screen.

3.4.12 Setting the marker thickness

1. Press the MENU switch.
2. Turn the adjustment dial to select **MARKER SETTING**, and press the ENT switch.
3. Turn the adjustment dial to select **Thickness**, and press the ENT switch.
4. Turn the adjustment dial to select the marker thickness, and press the ENT switch to enter the thickness.

NOTE

The line width of the frame marker and grid marker remain unchanged.

3.4.13 Adjusting the offset level of the brightness signals

1. Press the BRIGHT switch, and turn the adjustment dial to adjust the brightness value (offset level of the luminance signal).

NOTE

The offset level can be set within the range of -50.00 to +50.00% (Refer to section 4.5.)
To exit the brightness adjustment, press the BRIGHT switch again.
To return the brightness value to the initial setting, hold down the adjustment dial.

3.4.14 Adjusting the contrast of the brightness signals

1. Press the **CONTRAST** switch, and turn the adjustment dial to adjust the contrast value (contrast of the luminance signal).

NOTE

The contrast can be set within the range of 0.0 to 200.0% (Refer to section 4.5.)
To exit the contrast adjustment, press the **CONTRAST** switch again.
To return the contrast value to the initial setting, hold down the adjustment dial.

3.4.15 Adjusting the Pb (Cb) value

1. Press the **CHROMA** switch, and select **Pb (Cb)** only.
2. Turn the adjustment dial to adjust the **Pb (Cb)** value (color difference signal level).

NOTE

The color difference level can be set within the range of 0.0 to 200.0% (Refer to section 4.5.)
Each time the **CHROMA** switch is pressed, the value which is to be adjusted changes in the following sequence: **CHROMA** → **Pb (Cb)** → **Pr (Cr)** → exit adjustment.
To return the **Pb (Cb)** value to the initial setting, hold down the adjustment dial.

CAUTION

This adjustment takes effect only when **YPbPr** is selected by **Color Space**.

3.4.16 Adjusting the Pr (Cr) value

1. Press the CHROMA switch, and select Pr (Cr) only.
2. Turn the adjustment dial to adjust the Pr (Cr) value (color difference signal level).

NOTE

The color difference level can be set within the range of 0.0 to 200.0% (Refer to section 4.5.)
Each time the CHROMA switch is pressed, the value which is to be adjusted changes in the following sequence: CHROMA → Pb (Cb) → Pr (Cr) → exit adjustment.
To return the Pr (Cr) value to the initial setting, hold down the adjustment dial.

CAUTION

This adjustment takes effect only when YPbPr is selected by .

3.4.17 Adjusting the Pb (Cb) and Pr (Cr) values simultaneously (adjusting the chroma)

1. Press the CHROMA switch, and select Pb (Cb) and Pr (Cr) at the same time.
2. Turn the adjustment dial to adjust the chrominance value (color difference signal level).

NOTE

The color difference level can be set within the range of 0.0 to 200.0% (Refer to section 4.5.)
When Pb (Cb) or Pr (Cr) reaches the maximum or minimum level, no further adjustment is possible.
Each time the CHROMA switch is pressed, the value which is to be adjusted changes in the following sequence: CHROMA → Pb (Cb) → Pr (Cr) → exit adjustment.
To return both the Pb (Cb) and Pr (Cr) values to the initial settings, hold down the adjustment dial.

CAUTION

This adjustment takes effect only when YPbPr is selected by .

3.4.18 Multiplying the chroma signal value by 3

1. Press the MENU switch.
2. Turn the adjustment dial to select **OTHERS**, and press the ENT switch.
3. Turn the adjustment dial to select **Chroma Up**, and press the ENT switch to select ON or OFF.

NOTE

If the result of multiplying the value by 3 exceeds $\pm 109\%$, the increase will be limited to $\pm 109\%$. (Example: a 30% signal will be expanded to 90%, but when a 100% signal is multiplied by 3, it will be increased to 109% only.)

3.4.19 Adjusting the peaking value

1. Press the PEAK/HUE switch, and select Peaking.
2. Turn the adjustment dial to adjust the peaking value.

NOTE

The peaking value can be adjusted (in a range from 0 to 100) only when peaking is ON. Peaking is turned ON or OFF using MENU. Each time the PEAK/HUE switch is pressed, the value which is to be adjusted changes in the following sequence: Peaking → Hue → exit adjustment. To return the peaking value to the initial setting, hold down the adjustment dial.

CAUTION

When GBR has been selected by **Color Space**, the peaking level of the G signal is adjusted. Horizontal stripes may become conspicuous on the display if a significant amount of peaking is applied with an aspect ratio setting of 16:9 and with 1080i input signals.

CAUTION

Even when peaking has been set to ON, the peaking function will not take effect if the peaking adjustment amount is zero.

3.4.20 Setting peaking ON/OFF



1. Press the MENU switch.
2. Turn the adjustment dial to select **OTHERS**, and press the ENT switch.
3. Turn the adjustment dial to select **Peaking**, and press the ENT switch to select ON or OFF.



Even when peaking has been set to ON, the peaking function will not take effect if the peaking adjustment amount is zero.
When GBR has been selected by **Color Space**, the peaking will be that of G signal. Horizontal stripes may become conspicuous on the display if a significant amount of peaking is applied with an aspect ratio setting of 16:9

3.4.21 Adjusting the hue

1. Press the PEAK/HUE switch, and select Hue.
2. Turn the adjustment dial to adjust the hue value.

NOTE

The hue value can be adjusted in a range from -179.0 to 180.0°.
Each time the PEAK/HUE switch is pressed, the value which is to be adjusted changes in the following sequence: Peaking → Hue → exit adjustment.
To return the hue value to the initial setting, hold down the adjustment dial.



This adjustment takes effect only when YPbPr is selected by **Color Space**.
When GBR has been selected by **Color Space**, Hue will not be selected even when the PEAK/HUE switch is pressed.

3.4.22 Setting the filter ON/OFF

1. Press the MENU switch.
2. Turn the adjustment dial to select **OTHERS**, and press the ENT switch.
3. Turn the adjustment dial to select **Filter**, and press the ENT switch to select ON or OFF.

NOTE

The table below shows the combinations of the format and aspect ratio with which the filter is active.

FORMAT	ASPECT RATIO		Actual Size(HD) Twice Size(SD)	Blanking	UNDER SCAN
	4:3	16:9			
1035/60i	○	○	×	○	○
1080/60i	○	○	×	○	○
1080/30P	○	○	×	○	○
1080/25sF	○	○	×	○	○
1080/25p	○	○	×	○	○
1080/24sF	○	○	×	○	○
1080/24p	○	○	×	○	○
720/60p	○	○	×	○	○
720/50p	○	○	×	○	○
720/30p	○	○	×	○	○
720/25p	○	○	×	○	○
720/24p	○	○	×	○	○
525/59.94i	○	○	×	×	×
625/50i	○	○	×	×	×

CAUTION

The filter is not active when peaking is applied or with H delay or V delay.

3.4.23 Lighting the tally lamps

1. Press the switch to which the SDI A/B function has been allocated.

NOTE

The tally lamps (green and red) can be set to ON or OFF only using the remote controller. (Refer to section 2.2.)

CAUTION

The procedure for operating the tally lamps involves selecting the level. Operation is performed regardless of whether the REMOTE switch is ON or OFF.

3.4.24 Selecting the tally display method

1. Press the MENU switch.
2. Turn the adjustment dial to select **OTHERS**, and press the ENT switch.
3. Turn the adjustment dial to select **Tally Type**, and press the ENT switch to select Upper or Frame.

NOTE

At the "Upper" setting, the audio level meter and channel IDs are displayed at the top of the screen; at the "Frame" setting, the screen is given a border.

3.4.25 Selecting the channels to be displayed by the audio level meter

1. Press the MENU switch.
2. Turn the adjustment dial to select **OTHERS** or **AUDIO LEVEL METER**, and press the ENT switch.
3. Turn the adjustment dial to select **Audio CH**, and press the ENT switch to select channels 1 to 8 or channels 9 to 16.

3.4.26 Selecting the audio level meter display format

1. Press the MENU switch.
2. Turn the adjustment dial to select **AUDIO LEVEL METER**, and press the ENT switch.
3. Turn the adjustment dial to select **Change dir**, and press the ENT switch to select L to R, OUT to IN or Vertical.

NOTE

L to R ... The level on the meter changes from the left of the screen to the right of the screen when it is increased.

OUT to IN ... The level on the meter changes from the edges of the screen to the center of the screen when it is increased.

Vertical ... The level on the meter changes from the bottom of the screen to the top of the screen when it is increased.

(Refer to section 4.7.)

3.4.27 Selecting color display or monochrome display for the audio level meter

1. Press the MENU switch.
2. Turn the adjustment dial to select **AUDIO LEVEL METER**, and press the ENT switch.
3. Turn the adjustment dial to select **Cell Color**, and press the ENT switch to select COLOR or MONO.

NOTE

For details on the color layout of the audio level meter cells when the color or monochrome display is selected, refer to section 4.7.

3.4.28 Selecting the audio level meter channel layout

1. Press the MENU switch.
2. Turn the adjustment dial to select **AUDIO LEVEL METER**, and press the ENT switch.
3. Turn the adjustment dial to select **CH Order**, and press the ENT switch to select Type A or Type B.

NOTE

Type A ... Channels 1, 2, 3, 4 (or channels 9, 10, 11, 12) are displayed at the left of the screen and channels 5, 6, 7, 8 (or channels 13, 14, 15, 16) are displayed at the right.

Type B ... Channels 1, 3, 5, 7 (or channels 9, 11, 13, 15) are displayed at the left of the screen and channels 2, 4, 6, 8 (or channels 10, 12, 14, 16) are displayed at the right.

(Refer to section 4.7.)

3.4.29 Setting the audio level meter frame and information ON/OFF

1. Press the MENU switch.
2. Turn the adjustment dial to select **AUDIO LEVEL METER**, and press the ENT switch.
3. Turn the adjustment dial to select **Box&Info**, and press the ENT switch to select ON or OFF.

CAUTION

When OFF has been selected for Box&Info, the audio level meter is displayed only when the audio signals of the channels selected by Audio CH are superimposed onto the input signals. (Refer to section 4.7.)

3.4.30 Switching the audio level meter display ON/OFF

1. Press the MENU switch.
2. Turn the adjustment dial to select **DISPLAY SETTING** or **AUDIO LEVEL METER**, and press the ENT switch.
3. Turn the adjustment dial to select **Audio**, and press the ENT switch to select ON or OFF.

NOTE

Audio data complying with the BTA S-006B and SMPTE272M-A standards is displayed. For details on the audio level meter, refer to section 4.7.

CAUTION

No sound is output when composite signals are selected so the audio level meter will not work.

3.4.31 Switching the time code display ON/OFF

1. Press the MENU switch.
2. Turn the adjustment dial to select **DISPLAY SETTING**, and press the ENT switch.
3. Turn the adjustment dial to select **Time Code**, and press the ENT switch to select ON or OFF.

NOTE

The VITC complying with the ARIB STD-B4 version 2.0 standard is displayed as the time code. The time code is not displayed when composite and component signals have been selected.

3.4.32 Switching the input signal ID display ON/OFF

1. Press the MENU switch.
2. Turn the adjustment dial to select **DISPLAY SETTING**, and press the ENT switch.
3. Turn the adjustment dial to select **CH ID**, and press the ENT switch to select ON or OFF.

3.4.33 Switching the format display ON/OFF

1. Press the MENU switch.
2. Turn the adjustment dial to select **DISPLAY SETTING**, and press the ENT switch.
3. Turn the adjustment dial to select **Format**, and press the ENT switch to select ON or OFF.

NOTE

When the format display is set to ON, the format is displayed only for 3 seconds after it has changed.

3.4.34 Switching the error status display ON/OFF

1. Press the MENU switch.
2. Turn the adjustment dial to select **DISPLAY SETTING**, and press the ENT switch.
3. Turn the adjustment dial to select **Err Status**, and press the ENT switch to select ON or OFF.

NOTE

Included in the error status are whether subtitle data (captions) are present as well as the audio error count, CRC/EDH error count, Time and Last displays.



3.4.35 Setting the mask

1. Press the MENU switch.
2. Turn the adjustment dial to select **OTHERS**, and press the ENT switch.
3. Turn the adjustment dial to select **Half Mask** or **Mask**, and press the ENT switch to select ON or OFF.

NOTE

In the 16:9 display mode, all the area within 16:9 except for the 4:3 area is masked or half-masked. Mask takes priority if half mask and mask have been set to ON at the same time. The aspect ratios at which the mask and half mask functions become visibly valid are given below.

ASPECT RATIO / FORMAT	4:3	16:9	Actual Size (HD) Twice Size (SD)	Blanking	UNDER SCAN
HD input	×	○	×	○	○
SD input	×	○	×	×	×

CAUTION

Mask and half mask are released in the H delay mode.

3.4.36 Selecting the color space

1. Press the MENU switch.
2. Turn the adjustment dial to select **OTHERS**, and press the ENT switch.
3. Turn the adjustment dial to select **Color Space**, and press the ENT switch to select YPbPr or GBR.

CAUTION

Some items cannot be adjusted when GBR has been selected by **Color Space**.

3.4.37 Setting Green ON/OFF



1. Press the MENU switch.
2. Turn the adjustment dial to select **OTHERS**, and press the ENT switch.
3. Turn the adjustment dial to select **Green**, and press the ENT switch to select ON or OFF.



When this switch is set from ON to OFF or vice versa while monochrome or blue only is ON, monochrome or blue only will be set to OFF.

3.4.38 Setting Blue ON/OFF



1. Press the MENU switch.
2. Turn the adjustment dial to select **OTHERS**, and press the ENT switch.
3. Turn the adjustment dial to select **Blue**, and press the ENT switch to select ON or OFF.



When this switch is set from ON to OFF or vice versa while monochrome or blue only is ON, monochrome or blue only will be set to OFF.

3.4.39 Setting Red ON/OFF



1. Press the MENU switch.
2. Turn the adjustment dial to select **OTHERS**, and press the ENT switch.
3. Turn the adjustment dial to select **Red**, and press the ENT switch to select ON or OFF.



When this switch is set from ON to OFF or vice versa while monochrome or blue only is ON, monochrome or blue only will be set to OFF.



3.4.40 Setting H Delay ON/OFF

1. Press the MENU switch.
2. Turn the adjustment dial to select **OTHERS**, and press the ENT switch.
3. Turn the adjustment dial to select **H Delay**, and press the ENT switch to select ON or OFF.



Mask and half mask are released in the H delay mode.

3.4.41 Setting V Delay ON/OFF



1. Press the MENU switch.
2. Turn the adjustment dial to select **OTHERS**, and press the ENT switch.
3. Turn the adjustment dial to select **V Delay**, and press the ENT switch to select ON or OFF.

3.4.42 Allocating functions to the front panel switches

1. Press the MENU switch.
2. Turn the adjustment dial to select **SWITCH ASSIGN**, and press the ENT switch.
3. Turn the adjustment dial to select the switch whose setting is to be changed, and press the ENT switch.
4. Turn the adjustment dial to select the function to be allocated to the switch, and press the ENT switch.

NOTE

Functions can be assigned to four switches, F1 to F4.
 The same function can be allocated to different switches.
 The name of the function is highlighted while it is being allocated.
 To exit the list of function names, press the ESC key.

<Types of functions which can be allocated>

Marker, Half Mask, Mask, Mono, Blue Only, Green, Blue, Red, H Delay, V Delay, Aspect, Peaking, Time Code, Audio, CH ID, Format, Err Status, Chroma Up

3.4.43 Setting the remote controllers

1. Press the MENU switch.
2. Turn the adjustment dial to select **REMOTE SETTING**, and press the ENT switch.
3. Turn the adjustment dial to select the remote controller operation method or item, and press the ENT switch.
4. To change a setting item, turn the adjustment dial further to select the item to be allocated, and press the ENT switch to enter the item.

NOTE

Set **R1** to **R5** to **Non** if the corresponding remote controllers are not going to be used.

The remote controller operation method and recommended switches are given below.

When **Level** is selected: The slide switches are recommended.

The statuses of the functions are allocated for the open-circuit and short-circuit statuses respectively.

When **Edge** is selected: The pushbutton switches are recommended.

The functions are switched at the moment when the open-circuit status changes to the short-circuit status.

For details on the remote controllers, refer to section 4.8.

CAUTION

When the same item set by one remote controller has been set by another remote controller as well, the setting selected by the remote controller which performed the setting last will take effect. **Non** is set for the setting item for the remote controller which set the same item first, and no allocation will be made.

Set to **Non** for a remote controller which is not going to be used.

The control exercised by the remote controller will take effect only when the remote switch is at the ON position.

3.4.44 Giving names to the input signals

1. Press the MENU switch.
2. Turn the adjustment dial to select **INPUT CHANNEL ID**, and press the ENT switch.
3. Turn the adjustment dial to select the character to be changed, and press the ENT switch.
4. Turn the adjustment dial to select the character to change to, and press the ENT switch to enter it.

NOTE

Characters are changed one at a time. Upper-case and lower-case letters, numerals and basic symbols listed below can be used for the names, and up to 10 characters can be displayed.

List of usable characters

	!	"	#	\$	%	&	()	*	+	,	-	.	/	
0	1	2	3	4	5	6	7	8	9	:	;	<	=	>	?
@	A	B	C	D	E	F	G	H	I	J	K	L	M	N	O
P	Q	R	S	T	U	V	W	X	Y	Z	[\]	^	_
	a	b	c	d	e	f	g	h	i	j	k	l	m	n	o
p	q	r	s	t	u	v	w	x	y	z	{		}	~	

3.4.45 Displaying the color bars when no signals are input

1. Press the MENU switch.
2. Turn the adjustment dial to select **OTHERS**, and press the ENT switch.
3. Turn the adjustment dial to select **Color Bar**, and press the ENT switch to select ON or OFF.

NOTE

When the color bars are set to ON, the color bars generated internally can be displayed when no signals are input.

3.4.46 Executing the NTSC setup

1. Press the MENU switch.
2. Turn the adjustment dial to select **OTHERS**, and press the ENT switch.
3. Turn the adjustment dial to select **NTSC Setup**, and press the ENT switch to select the setting.

NOTE

Select OFF when NTSC signals with a setup of 0 are input; select 7.5IRE when signals with setup are input.

3.4.47 Saving and calling the settings

1. Press the MENU switch.
2. Turn the adjustment dial to select **LOAD & SAVE**, and press the ENT switch.
3. Turn the adjustment dial to select **Save** if the settings are to be saved or **Load** if the saved settings are to be loaded, and press the ENT switch.
4. Turn the adjustment dial to select the number of the setting to be saved or loaded, and press the ENT switch to enter it.

CAUTION

Do not turn off the power while **Wait** is displayed. If the power is turned off while the settings are being saved, all the user data saved in the monitor will be destroyed, and the initial settings will be established when the power is next turned on.

3.4.48 Returning the settings to their initial values

■ Resetting the error count (Refer to section 4.9)

1. Press the MENU switch.
2. Turn the adjustment dial to select **RESET CALL**, and press the ENT switch.
3. Turn the adjustment dial to select **Error Reset**, and press the adjustment dial.

NOTE

The elapsed time (Time) is not reset.

■ Initializing the settings of the currently selected channels (Refer to section 4.9)

1. Press the MENU switch.
2. Turn the adjustment dial to select **RESET CALL**, and press the ENT switch.
3. Turn the adjustment dial to select **Channel Reset**, and press the adjustment dial.

■ Initializing the settings of all the channels (Refer to section 4.9)

1. Press the MENU switch.
2. Turn the adjustment dial to select **RESET CALL**, and press the ENT switch.
3. Turn the adjustment dial to select **Factory Default**, and press the adjustment dial.

NOTE

Neither the error count nor elapsed time (Time) is reset.

CAUTION

The settings which have been saved as fixed user data are not initialized.

3.4.49 Selecting the color temperature

1. Press the MENU switch.
2. Turn the adjustment dial to select **PICTURE QUALITY**, and press the ENT switch.
3. Turn the adjustment dial to select **Color Temperature**, and press the ENT switch.
4. Turn the adjustment dial to select 5500K, 6500K or 9300K as the color temperature, and press the ENT switch.

NOTE

It is possible to select 5500K, 6500K or 9300K as the color temperature. The G brightness, B brightness, R brightness, G contrast, B contrast, R contrast, G gamma, B gamma and R gamma settings differ depending on the color temperature selected.

3.4.50 Adjusting the G brightness

1. Press the MENU switch.
2. Turn the adjustment dial to select **PICTURE QUALITY**, and press the ENT switch.
3. Turn the adjustment dial to select **G-Bright**, and press the ENT switch.
4. Turn the adjustment dial to adjust the G brightness value, and press the ENT switch.

NOTE

The brightness value can be set within the range of -50.00 to +50.00% (Refer to section 4.5.) The setting of this item differs depending on the color temperature.

3.4.51 Adjusting the B brightness

1. Press the MENU switch.
2. Turn the adjustment dial to select **PICTURE QUALITY**, and press the ENT switch.
3. Turn the adjustment dial to select **B-Bright**, and press the ENT switch.
4. Turn the adjustment dial to adjust the B brightness value, and press the ENT switch.

NOTE

The brightness value can be set within the range of -50.00 to +50.00% (Refer to section 4.5.) The setting of this item differs depending on the color temperature.

3.4.52 Adjusting the R brightness

1. Press the MENU switch.
2. Turn the adjustment dial to select **PICTURE QUALITY**, and press the ENT switch.
3. Turn the adjustment dial to select **R-Bright**, and press the ENT switch.
4. Turn the adjustment dial to adjust the R brightness value, and press the ENT switch.

NOTE

The brightness value can be set within the range of -50.00 to +50.00% (Refer to section 4.5.) The setting of this item differs depending on the color temperature.

3.4.53 Adjusting the G contrast

1. Press the MENU switch.
2. Turn the adjustment dial to select **PICTURE QUALITY**, and press the ENT switch.
3. Turn the adjustment dial to select **G-Contrast**, and press the ENT switch.
4. Turn the adjustment dial to adjust the G contrast value, and press the ENT switch.

NOTE

The contrast value can be set within the range of 0.0 to 200.0% (Refer to section 4.5.) The setting of this item differs depending on the color temperature.

3.4.54 Adjusting the B contrast

1. Press the MENU switch.
2. Turn the adjustment dial to select **PICTURE QUALITY**, and press the ENT switch.
3. Turn the adjustment dial to select **B-Contrast**, and press the ENT switch.
4. Turn the adjustment dial to adjust the B contrast value, and press the ENT switch.

NOTE

The contrast value can be set within the range of 0.0 to 200.0% (Refer to section 4.5.) The setting of this item differs depending on the color temperature.

3.4.55 Adjusting the R contrast

1. Press the MENU switch.
2. Turn the adjustment dial to select **PICTURE QUALITY**, and press the ENT switch.
3. Turn the adjustment dial to select **R-Contrast**, and press the ENT switch.
4. Turn the adjustment dial to adjust the R contrast value, and press the ENT switch.

NOTE

The contrast value can be set within the range of 0.0 to 200.0% (Refer to section 4.5.) The setting of this item differs depending on the color temperature.

3.4.56 Adjusting the G gamma

1. Press the MENU switch.
2. Turn the adjustment dial to select **PICTURE QUALITY**, and press the ENT switch.
3. Turn the adjustment dial to select **G-Gamma**, and press the ENT switch.
4. Turn the adjustment dial to adjust the G gamma value, and press the ENT switch.

NOTE

The contrast value can be set within the range of 1.00 to 4.00.
The setting of this item differs depending on the color temperature.

3.4.57 Adjusting the B gamma

1. Press the MENU switch.
2. Turn the adjustment dial to select **PICTURE QUALITY**, and press the ENT switch.
3. Turn the adjustment dial to select **B-Gamma**, and press the ENT switch.
4. Turn the adjustment dial to adjust the B gamma value, and press the ENT switch.

NOTE

The contrast value can be set within the range of 1.00 to 4.00. The setting of this item differs depending on the color temperature.

3.4.58 Adjusting the R gamma

1. Press the MENU switch.
2. Turn the adjustment dial to select **PICTURE QUALITY**, and press the ENT switch.
3. Turn the adjustment dial to select **R-Gamma**, and press the ENT switch.
4. Turn the adjustment dial to adjust the R gamma value, and press the ENT switch.

NOTE

The contrast value can be set within the range of 1.00 to 4.00. The setting of this item differs depending on the color temperature.

3.4.59 Adjusting the output volume level

1. Press the AUDIO switch to select Volume.
2. Turn the adjustment dial to adjust the volume level.

NOTE

The volume level can be set within the range of 0 to 255.
 Each time the AUDIO switch is pressed, the switch setting changes in the following sequence: Volume → L_CH → R_CH → exit adjustment.
 To return the volume level to the initial setting, hold down the adjustment dial.
 When the AUDIO switch is held down, the output sound is muted.
 The muting status is released by holding down the AUDIO switch again or re-adjusting the volume level.

3.4.60 Setting the output audio channel

1. Press the AUDIO switch to select L_CH or R_CH.
2. Turn the adjustment dial to set the output channel.

NOTE

The audio channels are channels 1 through 16. The same channel can be selected for the left and right channels (in which case monaural sound will be output).
Each time the AUDIO switch is pressed, the switch setting changes in the following sequence: Volume → L_CH → R_CH → exit adjustment.
To return the channel to the initial setting, hold down the adjustment dial.

3.4.61 Changing the color of the markers

1. Press the MENU switch.
2. Turn the adjustment dial to select **DISPLAY SETTING**, and press the ENT switch.
3. Turn the adjustment dial to select **Mark Color**, and press the ENT switch.
4. Turn the adjustment dial to change the display color, and press the ENT switch to enter the change.

3.4.62 Changing the color of the time code

1. Press the MENU switch.
2. Turn the adjustment dial to select **DISPLAY SETTING**, and press the ENT switch.
3. Turn the adjustment dial to select **TC Color**, and press the ENT switch.
4. Turn the adjustment dial to change the display color, and press the ENT switch to enter the change.

3.4.63 Changing the color of the characters

1. Press the MENU switch.
2. Turn the adjustment dial to select **DISPLAY SETTING**, and press the ENT switch.
3. Turn the adjustment dial to select **Info Color**, and press the ENT switch.
4. Turn the adjustment dial to change the display color, and press the ENT switch to enter the change.

NOTE

At the Info Color setting, the display color of all the information displayed except for the markers and time code is changed.

3.4.64 Displaying all the settings

1. Hold down the MENU switch.

NOTE

Information on the settings which will be restored to the initial settings by **Channel Reset** and on the settings which will be restored to the initial settings by **Factory Default** are displayed in this sequence. For the items which are displayed, refer to section 4.9.

4

MAIN SPECIFICATIONS

4.1 Input formats

Format		Frame Rate (Hz)	Active Line per Frame	Total Line Per Frame	Line Frequency (kHz)	Samples per Active Line	Samples per Total Line	Scanning *1	*2
1035i/60	1035i/59.94	30/1.001	1035	1125	33.72	1920	2200	i	(1)
	1035i/60	30	1035	1125	33.75	1920	2200	i	
1080i/60	1080i/59.94 1080sF/29.97	30/1.001	1080	1125	33.72	1920	2200	i sF	(1) (3)
	1080i/60 1080sF/30	30	1080	1125	33.75	1920	2200	i sF	(1) (3)
1080p/30	1080p/29.97	30/1.001	1080	1125	33.72	1920	2200	p	(2)
	1080p/30	30	1080	1125	33.75	1920	2200	p	
1080sF/25 (1080i/50)	1080sF/25 1080i/50	25	1080	1125	28.13	1920	2640	sF i	(3) (2)
1080p/25	1080p/25	25	1080	1125	28.13	1920	2640	p	(2)
1080sF/24	1080sF/23.98	24/1.001	1080	1125	26.97	1920	2750	sF	(3)
	1080sF/24	24	1080	1125	27.00	1920	2750	sF	
1080p/24	1080p/23.98	24/1.001	1080	1125	26.97	1920	2750	p	(2)
	1080p/24	24	1080	1125	27.00	1920	2750	p	
720p/60	720p/59.94	60/1.001	720	750	44.96	1280	1650	p	(4)
	720p/60	60	720	750	45.00	1280	1650	p	
720p/50	720p/50	50	720	750	36.00	1280	1980	p	(4)
720p/30	720p/29.97	30/1.001	720	750	22.48	1280	3300	p	(4)
	720p/30	30	720	750	22.50	1280	3300	p	
720p/25	720p/25	25	720	750	18.75	1280	3960	p	(4)
720p/24	720p/23.98	24/1.001	720	750	17.98	1280	4125	p	(4)
	720p/24	24	720	750	18.00	1280	4125	p	
525i/60	525i/59.94	60/1.001	487	525	15.73	720	858	i	(5)
625i/50	625i/50	50	576	625	15.63	720	864	i	(6)

*1: Abbreviations used for scanning systems

i = Interlace
sF = Segmented Frame
p = Progressive

*2: Standard

(1) BTA S-001B, 2B, 4B complied with, (2) SMPTE 274M complied with,
(3) RP 211-2000 complied with, (4) SMPTE 296M complied with,
(5) SMPTE 259M complied with, (6) ITU-R BT.601-5 complied with

4.2 Input signal systems

Input specification	SDI input specification	Specification
SDI input	HDTV	BTA S-004B and SMPTE 292M standards complied with, NRZI SDI signal
	SDTV	SMPTE 259M standard complied with, NRZI SDI signal * Reception is guaranteed for a distance of 100 meters.
	Field (frame) frequency, 60.00/59.94 [Hz], etc. automatically tracked Automatic tracking of input formats enabled	

Component input specification	Specification
COMPONENT Input	-BTA S-001B, SMPTE 274M, SMPTE 296M standard complied with -Image formato 1080i, 1035i, 720p complied -Filed frequency rate 60Hz, 60/1.001 Automaticly support

Composite input specification	Specification
NTSC (525/60)	SMPTE 170M standard complied with
PAL (625/50)	ITU-R624-4 complied with (PAL-M and PAL-N are not supported)

4.3 Display systems

Display system	Specification		
Liquid crystal	a-Si TFT LCD		
Colors displayed	16,777,216 colors		
Contrast ratio	700:1 (Typ)		
Response time	25ms (Typ) (Ton+Toff 10%↔90%)		
Angle of view	170° vertically, 170° horizontally		
Brightness	350 cd/m2 (max.)		
Screen size	15 inches		
Resolution	1024 (H) × 768 (V) pixels		
Image area	Aspect ratio indication	Display size	
		HDTV	SDTV
	4:3	1024 (H) × 768 (V) Pixels	1024 (H) × 768 (V) Pixels
	16:9	1024 (H) × 576 (V) Pixels	1024 (H) × 576 (V) Pixels
	Actual Size	1024 (H) × 768 (V) Pixels	
	Twice Size	1024 (H) × 768 (V) Pixels	
Blanking/Under Scan	960 (H) × 540 (V) Pixels	720 (H) × 487 (V) Pixels (525i) 720 (H) × 576 (V) Pixels (625i)	
Pixel pitch	0.297 (W) × 0.297 (H) mm		

4.4 Headphones output format

Maximum output	10mW \pm 5% (32 Ω /1kHz)
Frequency response	100 Hz to 20 kHz (0 dB to -3 dB) The audio signals are output when 48 kHz embedded audio is superimposed onto the SDI signals.

4.5 Concerning the adjustment values

■ Brightness

The offset level of the luminance signal can be varied in the range of -50.00 to +50.00%. This applies to the G brightness, B brightness and R brightness as well.

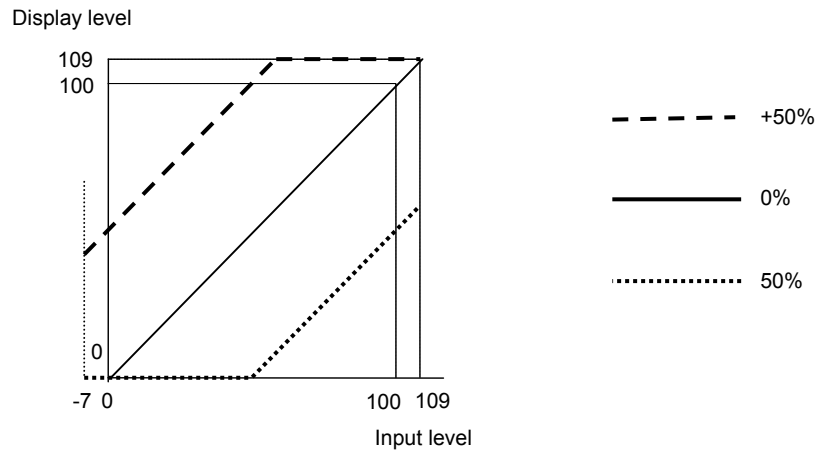

■ Contrast

The level of the luminance signal can be varied in the range of 0.0 to 200.0%. This applies to the G brightness, B brightness and R brightness as well.

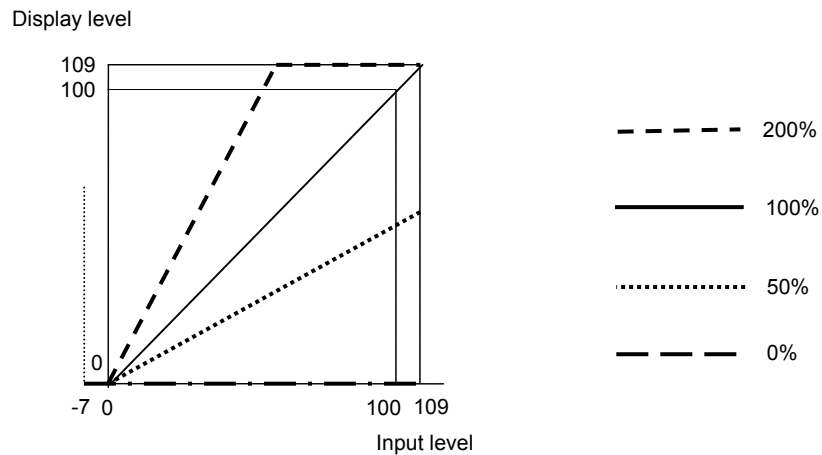

■ Chroma, Pb (Cb), Pr (Cr)

The level of the chrominance signals can be varied in the range of 0.0 to 200.0%.

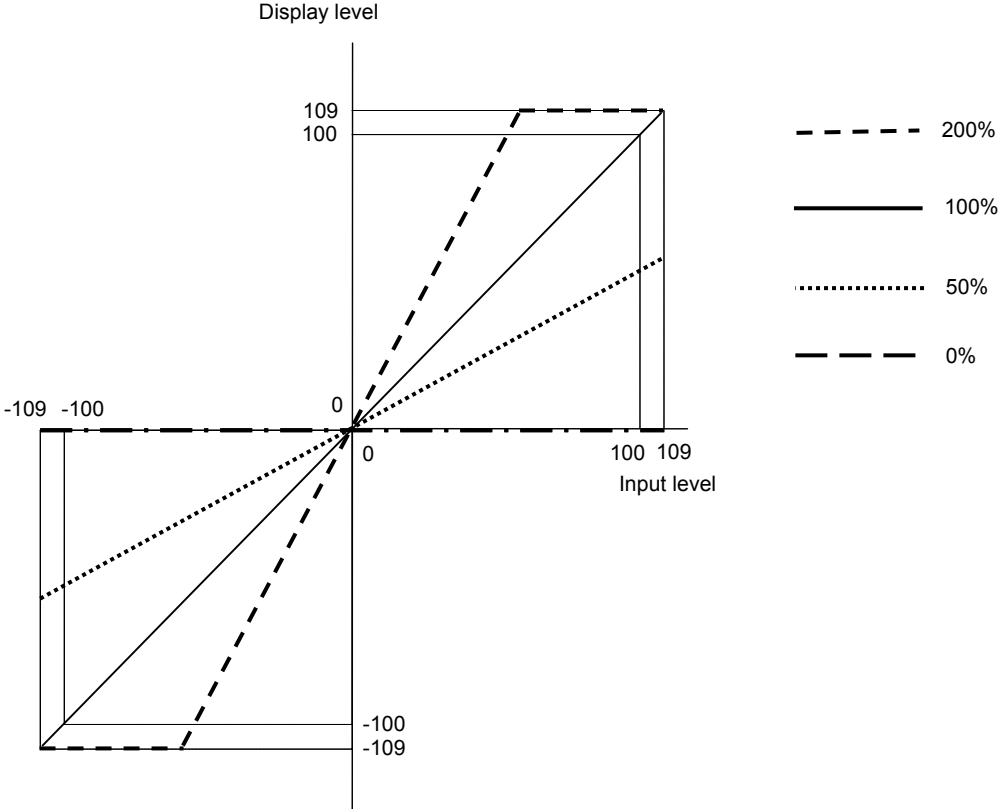

4.6 Concerning the aspect ratios

■ 4 : 3

When HD signals are input: The screen is filled with the display of the 4:3 area as the video area.

When SD signals are input: The screen is filled with the display of the entire video area.

■ 16 : 9

When HD signals are input: The video area is displayed with a 16:9 aspect ratio (1024 × 576 dots)

When SD signals are input: The video area with an aspect ratio of 4:3 is extended horizontally, and displayed with a 16:9 aspect ratio (1024 × 576 dots).

■ Actual Size

HD input signals only: One pixel of the input signals is displayed with one pixel on the LCD screen, that is to say, at the 1:1 ratio.

* Interlaced signals are doubled in size in the vertical direction.

■ Twice Size

When SD signals are input: One pixel of the input signals is displayed as 8 pixels (2 × 4) on the LCD display.

■ Blanking

The images are reduced in size and displayed including the blanking period.

■ Under Scan

The images are reduced in size and displayed excluding the blanking period.

4.7 Concerning the audio level meter

The audio level meter indicates the audio level in compliance with the BTA S-006B and SMPTE 272M-A audio standards.

4.7.1 Audio levels and cell color scheme

The table below shows the audio levels and color scheme used for the cells. The cell numbers in the CELL NO. column change in response to the display format used by the audio level meter.

CELL NO.	Audio level	Color scheme	
		Color display	Monochrome display
1	0dB	Red	White
2	-3dB or more but less than 0dB	Orange	Gray 192 (*1)
3	-6dB or more but less than -3dB	Orange	Gray 192 (*1)
4	-9dB or more but less than -6dB	Orange	Gray 192 (*1)
5	-12dB or more but less than -9dB	Orange	Gray 192 (*1)
6	-15dB or more but less than -12dB	Orange	Gray 192 (*1)
7	-18dB or more but less than -15dB	Orange	Gray 192 (*1)
8	-20dB or more but less than -18dB	Yellow	White
9	-24dB or more but less than -20dB	Green	Gray 160 (*2)
10	-30dB or more but less than -24dB	Green	Gray 160 (*2)
11	-36dB or more but less than -30dB	Green	Gray 160 (*2)
12	-42dB or more but less than -36dB	Green	Gray 160 (*2)
13	-48dB or more but less than -42dB	Green	Gray 160 (*2)
14	-56dB or more but less than -48dB	Green	Gray 160 (*2)
15	-60dB or more but less than -56dB	Green	Gray 160 (*2)
16	Audio signals present	Green	Gray 160 (*2)

*1: Gray with G:192, B:192 and R:192

*2: Gray with G:160, B:160 and R:160

4.7.2 Display formats and cell layout

■ Display format: With the L to R cell layout

The figures below show the cell numbers (Refer to section 4.7.1.) What is displayed on the audio level meter changes from left to right as the audio level is increased.

CH	-60	-50	-40	-30	-20	-18	-12	-6	0	dB						
1	16	15	14	14	12	11	10	9	8	7	6	5	4	3	2	1
2	16	15	14	14	12	11	10	9	8	7	6	5	4	3	2	1
3	16	15	14	14	12	11	10	9	8	7	6	5	4	3	2	1
4	16	15	14	14	12	11	10	9	8	7	6	5	4	3	2	1

Level meter at the left of the screen

CH	-60	-50	-40	-30	-20	-18	-12	-6	0	dB						
5	16	15	14	14	12	11	10	9	8	7	6	5	4	3	2	1
6	16	15	14	14	12	11	10	9	8	7	6	5	4	3	2	1
7	16	15	14	14	12	11	10	9	8	7	6	5	4	3	2	1
8	16	15	14	14	12	11	10	9	8	7	6	5	4	3	2	1

Level meter at the right of the screen

■ Display format: With the OUT to IN cell layout

The figures below show the cell numbers (Refer to section 4.7.1.) What is displayed on the audio level meter at the left of the screen changes from left to right as the audio level is increased. Conversely, what is displayed on the audio level meter at the right of the screen changes from right to left as the audio level is increased.

CH	-60	-50	-40	-30	-20	-18	-12	-6	0	dB						
1	16	15	14	13	12	11	10	9	8	7	6	5	4	3	2	1
2	16	15	14	13	12	11	10	9	8	7	6	5	4	3	2	1
3	16	15	14	13	12	11	10	9	8	7	6	5	4	3	2	1
4	16	15	14	13	12	11	10	9	8	7	6	5	4	3	2	1

Level meter at the left of the screen

dB	0	-6	-12	-18	-20	-30	-40	-50	-60	CH						
5	1	2	3	4	5	6	7	8	9	10	11	12	13	14	15	16
6	1	2	3	4	5	6	7	8	9	10	11	12	13	14	15	16
7	1	2	3	4	5	6	7	8	9	10	11	12	13	14	15	16
8	1	2	3	4	5	6	7	8	9	10	11	12	13	14	15	16

Level meter at the right of the screen

■ **Display format: With the vertical cell layout**

The figures below show the cell numbers (Refer to section 4.7.1.) What is displayed on the audio level meter changes from bottom to top as the audio level is increased. Two types, type A and type B, can be selected as the channel display pattern. (Refer to section 4.7.3.)

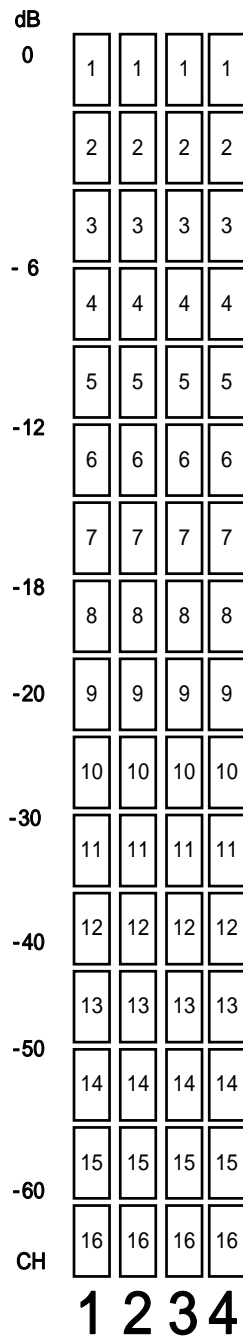

Level meter at the left of the screen
(Type A)

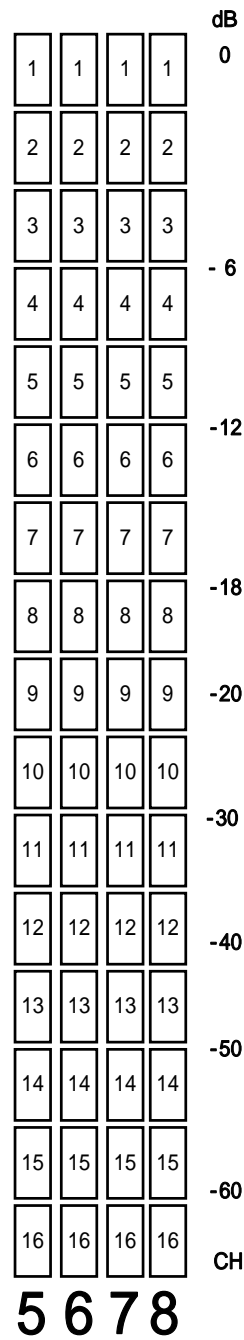

Level meter at the right of the screen
(Type A)

4.7.3 Audio level meter settings

■ Selecting the display format

The display format can be selected by **Change dir** under **AUDIO LEVEL METER** on the menu screen.

- L to R ... What is displayed on the audio level meter changes from left to right as the audio level is increased.
- OUT to IN ... What is displayed on the audio level meter changes from the edges of the screen to the center as the audio level is increased.
- Vertical ... What is displayed on the audio level meter changes from bottom to top as the audio level is increased.

■ Switching between the color display and monochrome display

The display can be switched between color and monochrome by **Cell Color** under **AUDIO LEVEL METER** on the menu screen.

- COLOR ... The cell color scheme is set to color.
- MONO ... The cell color scheme is set to monochrome.

* For details on the color scheme, refer to “4.7.1 Audio levels and cell color scheme.”

■ Switching the channel layout

The channel layout can be switched by **CH Order** under **AUDIO LEVEL METER** on the menu screen.

- Type A ... Channels 1, 2, 3 and 4 (channels 9, 10, 11 and 12) are displayed at the left of the screen, and channels 5, 6, 7 and 8 (channels 13, 14, 15 and 16) at the right.
- Type B ... Channels 1, 3, 5 and 7 (channels 9, 11, 13 and 15) are displayed at the left of the screen, and channels 2, 4, 6 and 8 (channels 10, 12, 14 and 16) at the right.

* When Vertical has been selected as the channel format and Type B is selected, the channels of the audio level meter at the right of the screen are laid out in the sequence of channels 8, 6, 4 and 2 (channels 16, 14, 12 and 10) from the left. At all other settings, the channels are laid out in ascending order from the left.

■ Turning the frame and information ON and OFF

The frame and information can be turned ON and OFF by **Box&Info** under **AUDIO LEVEL METER** on the menu screen. When OFF is selected for Box&Info, the audio level meter is displayed only when the audio signals of the channels selected by Audio CH are superimposed on the input signals.

4.8 Concerning the remote controllers

4.8.1 Examples of operations

■ Concerning the edge operation

The switch command for the edge operation is executed when it is verified that the control signal has gone from low to high.

Example: SDI_A/SDI_B

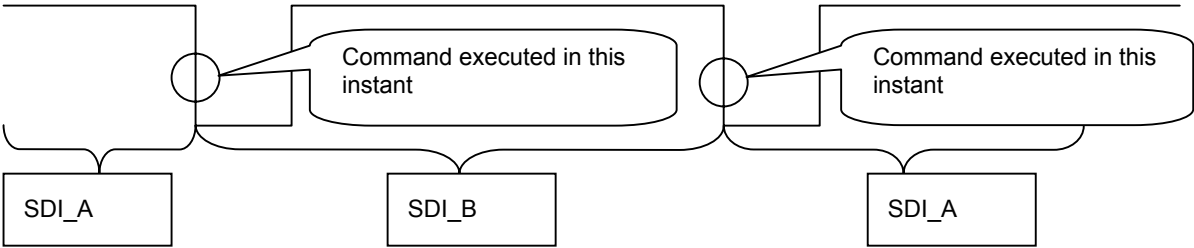

■ Concerning the level operation

Settings are allocated to the control signal low and high levels for the level operation.

Example: SDI_A/SDI_B

SDI_A is allocated to high and SDI_B to low so the operation will be as shown below.

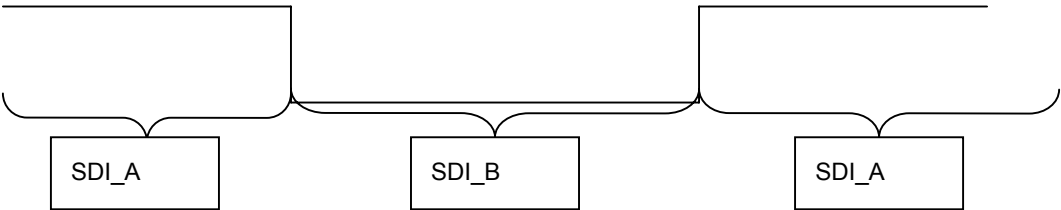

4.8.2 Settings during level operations

Display	Function	Status during level operation	
		Open (high)	Make (low)
SDI_A/B	SDI A/B switching	SDI_A	SDI_B
SDI/Analog	SDI/ANALOG switching	SDI	ANALOG
VBS/CMPNT	VBS/COMPONENT switching	COMPOSITE	COMPONENT
Marker	Marker ON/OFF	OFF	ON
H Mask	Half mask ON/OFF	OFF	ON
Mask	Mask ON/OFF	OFF	ON
MONO	Monochrome/color switching	Color	MONO
Blue Only	Blue only/ color switching	Color	Blue Only
Green	ON/OFF of green component in images	ON	OFF
Blue	ON/OFF of blue component in images	ON	OFF
Red	ON/OFF of red component in images	ON	OFF
H Delay	ON/OFF of horizontal delay	OFF	ON
V Delay	ON/OFF of vertical delay	OFF	ON
ASPECT	Aspect ratio type A/type B switching	TYPE A	TYPE B
Peaking	Peaking ON/OFF	ON	OFF
Time Code	Display/non-display	ON	OFF
Audio	Display/non-display	ON	OFF
CH ID	Display/non-display	ON	OFF
Format	Display/non-display	ON	OFF
Err Status	Display/non-display	ON	OFF
Chroma Up	Chroma boost function ON/OFF	OFF	ON
Non	Invalid		

4.9 Settings when initialization is performed

The settings established when the DM-3016-F was shipped from the factory and when they have been initialized are listed below.

4.9.1 Common setting items

The settings for the following items are the same whether for the SDI A, SDI B VBS or COMPONENT signals.

These settings are "Factory Default" settings, and they are not initialized unless the settings of all the channels are initialized.

Setting item	Setting/adjustment range	Initial value
Current CH	SDI A/ SDI B/VBS/COMPOSITE	SDI A
Color Temperature	9300K/6500K/5500K	6500K
G-Brightness	-50.0 to +50.0%	0.0%
B-Brightness	-50.0 to +50.0%	0.0%
R-Brightness	-50.0 to +50.0%	0.0%
G-Contrast	0.0 to 200.0%	100.0%
B-Contrast	0.0 to 200.0%	100.0%
R-Contrast	0.0 to 200.0%	100.0%
G-Gamma	1.00 to 4.00	2.20
B-Gamma	1.00 to 4.00	2.20
R-Gamma	1.00 to 4.00	2.20
Select Marker	Frame, Center, 95%, 93%, 88%, 80%, 4:3, 13:9, 14:9, 2.35:1, 1.85:1, 1.66:1, Grating, User, Box	Frame, Center
Box H position	0 to 1023pix	166pix
Box V position	0 to 767pix	125pix
Box Width	1 to 1024pix	692pix
Box Height	1 to 768pix	518pix
User Marker H	0 to 100%	85%
User Marker V	0 to 100%	85%
Marker Thickness	×1/×2/×3/×4	×1
Audio CH	1-8Ch/9-16Ch	1-8Ch
Tally Type	Upper/Frame	Upper
Color Bar	ON/OFF	OFF
Aspect	TYPE A/TYPE B	TYPE A
Aspect A-HD	4:3/16:9/Actual Size/Blanking/Under Scan	16:9
Aspect A-SD	4:3/16:9/Twice Size/Blanking/Under Scan	4:3
Aspect B-HD	4:3/16:9/Actual Size/Blanking/Under Scan	4:3
Aspect B-SD	4:3/16:9/Twice Size/Blanking/Under Scan	16:9
Marker	ON/OFF	OFF
Mask	ON/OFF	OFF
Half Mask	ON/OFF	OFF
Time Code	ON/OFF	ON
Audio Level Meter	ON/OFF	ON

Setting item	Setting/adjustment range	Initial value
Change dir	L to R/OUT to IN/Vertical	L to R
Cell Color	COLOR/MONO	COLOR
CH Order	type A/type B	type A
Box&Info	ON/OFF	ON
Mute	ON/OFF	OFF
CH ID	ON/OFF	ON
Format	ON/OFF	ON
Err Status	ON/OFF	ON
NTSC Setup	7.5IRE/OFF	OFF
Information Color	All 63 colors (excluding black) for G: 0 to 3; B: 0 to 3, R: 0 to 3	White3 (G:3, B:3, R:3)
Marker Color	All 64 colors for G: 0 to 3; B: 0 to 3, R: 0 to 3	White3 (G:3, B:3, R:3)
Time Code Color	All 63 colors (excluding black) for G: 0 to 3; B: 0 to 3, R: 0 to 3	White3 (G:3, B:3, R:3)
Remote Control * State (* : R1 to R5)	Level/Edge	Level
Remote Control * (* : R1 to R5)	SDI A/B, SDI/VBS, Marker, Half Mask, Mask, Mono, Blue Only, Green, Blue, Red, H Delay, V Delay, Aspect, Peaking, Time Code, Audio, CH ID, Format, Err Status, Chroma Up, Non	Non
Front Switch Assign F1	Marker, Half Mask, Mask, Mono, Blue Only, Green, Blue, Red, H Delay, V Delay, Aspect, Peaking, Time Code, Audio, CH ID, Format, Err Status, Chroma Up	Aspect
Front Switch Assign F2		Mono
Front Switch Assign F3		Marker
Front Switch Assign F4		Peaking

4.9.2 Setting items by channel

The following items are set separately for the SDI A, SDI B, VBS and COMPONENT signals. These settings are initiated either by "Channel Reset" or "Factory Default."

Setting item	Setting/adjustment range	Initial value		
		SDI A	SDI B	COMPOSITE
Channel ID		SDI A	SDI B	COMPOSITE
Format	All 15 types	Auto	Auto	Auto
Brightness	-50.0 to +50.0%	0.0%	0.0%	0.0%
Contrast	0.0 to 200.0%	100.0%	100.0%	100.0%
Pb(Cb)	0.0 to 200.0%	100.0%	100.0%	100.0%
Pr(Cr)	0.0 to 200.0%	100.0%	100.0%	100.0%
Hue	-179.0 to 180.0°	0.0°	0.0°	0.0°
Peaking Level	0 to 100	0	0	0
Peaking	ON/OFF	ON	ON	ON
Filter	ON/OFF	ON	ON	ON
Mono	ON/OFF	OFF	OFF	OFF
Blue Only	ON/OFF	OFF	OFF	OFF
Green	ON/OFF	ON	ON	ON
Blue	ON/OFF	ON	ON	ON
Red	ON/OFF	ON	ON	ON
Color Space	YPbPr/GBR	YPbPr	YPbPr	YPbPr
H Delay	ON/OFF	OFF	OFF	OFF
V Delay	ON/OFF	OFF	OFF	OFF
Volume	0 to 255	128	128	N/A
L_CH	1 to 16CH	1CH	1CH	N/A
R_CH	1 to 16CH	2CH	2CH	N/A
Chroma Up	ON/OFF	OFF	OFF	OFF

4.9.3 Resetting the error count and elapsed time

The following status values are initialized by "Error Reset." They are not initiated either by "Channel Reset" or "Factory Default."

Status	Initial value	Remarks
Audio Err	0000000	
CRC,EDH	0000000	
Last	00:00:00	Audio error, and CRC, EDH elapsed time

* Subtitles and Time are not initialized.

4.10 General specifications

Table 4.1 Operating environment and ratings for DM-3016-F (main unit)

Operating temperature range	0 to 40°C (no condensation must be allowed to form)
Storage temperature range	-10 to 60°C
Operating humidity range	30 to 80%RH (surrounding temperature must be in the 0 to 40°C range and no condensation must be allowed to form)
Storage humidity range	10 to 90%RH (surrounding temperature must be in the 0 to 40°C range and no condensation must be allowed to form)
Rated voltage	AC 100 to 240V 50/60Hz
Power consumption (main unit)	40W (Typ) (main unit only)
LCD service life	50,000 hours (with LCD backlight brightness reduced to one-half) (*)
Dimensions	350 (W) × 280 (H) × 94 (D) mm (main unit only)
Weight	Approx. 3.50 kg (main unit only. 3.84 kg when the self-standing plate available as a standard accessory is mounted)

* The value given for the LCD service life is estimated and not guaranteed.

4.11 Outline drawings

4.11.1 Outline drawings of DM-3016-F (main unit)

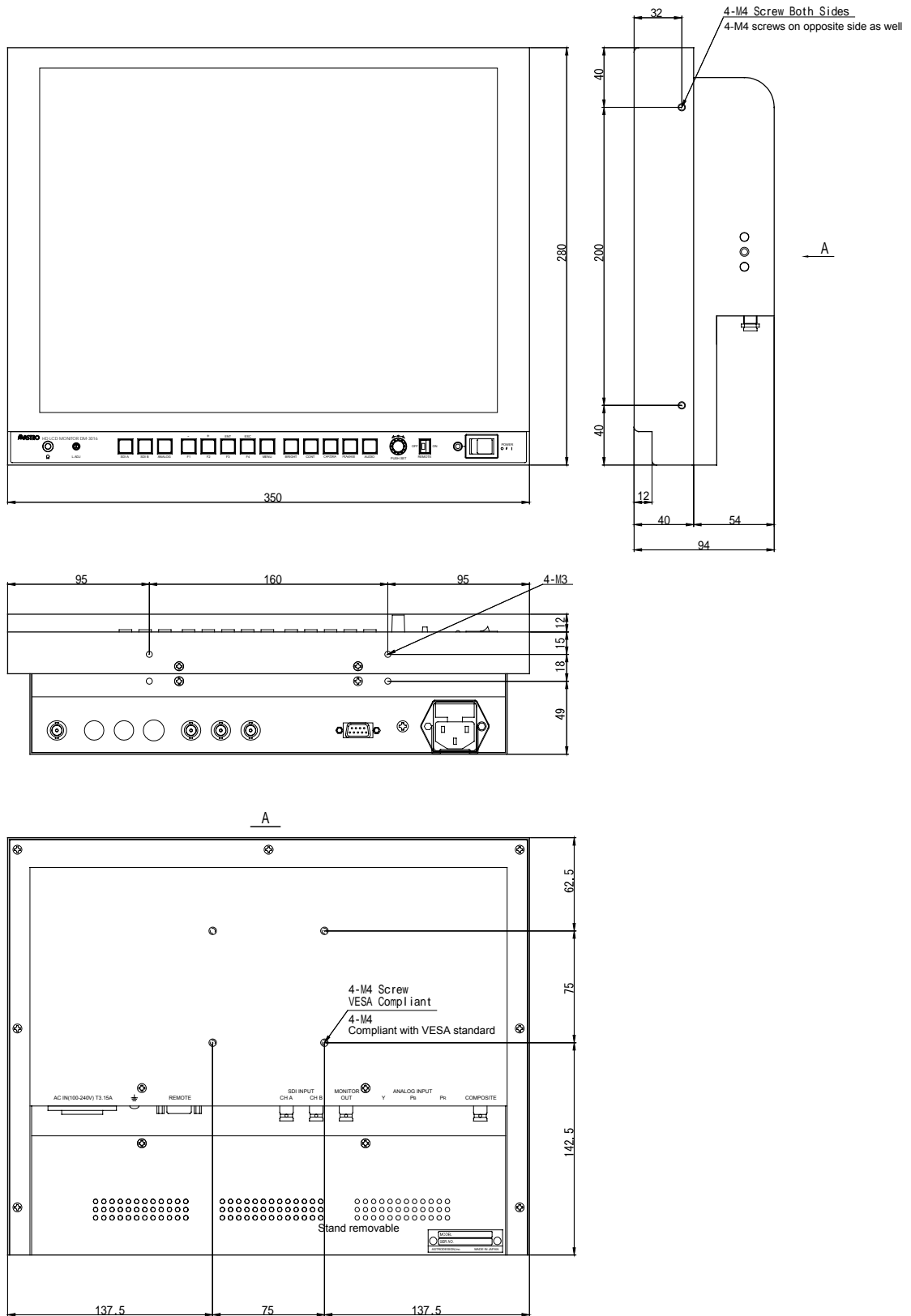

4.11.2 Outline drawing of self-standing plate (standard accessory)

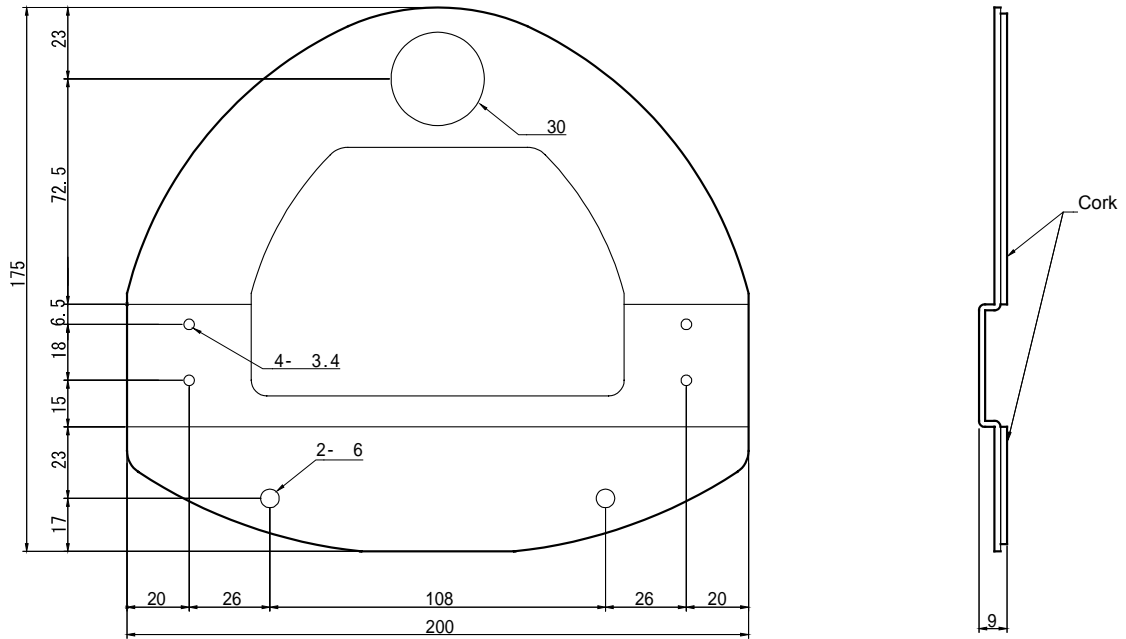

5

STANDARD AND OPTIONAL ACCESSORIES

5.1 Standard accessories

DM-3016-F instruction manual (what you are reading)	1 copy
AC cable	1 pc
Stickers for front panel switches	1 sheet
Self-standing plate	1 pc
Plate mounting screws (M3 × L6 binding screws)	4 pcs

5.2 Optional accessories

Provided for the DM-3016-F are rack-mounting adapters as optional accessories for the LCD unit. Further optional accessories are released from time to time so contact Astrodesign for information on the latest options available.[]

Accessory	Model
Single rack-mounting adapters	DM-3016-F- 04

6

MAINTENANCE AND OTHER PROCEDURES

When the monitor does not operate properly

Symptom	What is to be checked
The image is not displayed properly.	<ul style="list-style-type: none"> ● Has the correct format been set? ● Has Color Space (YPbPr/GBR) been set properly?
The front panel switches fail to operate.	<ul style="list-style-type: none"> ● Is the REMOTE switch at the ON position?
The remote controller fails to operate.	<ul style="list-style-type: none"> ● Check the method used to operate the remote controller. Have the correct level, edge, etc. been selected? ● Is the REMOTE switch at ON?
When the REMOTE switch is set to ON, the markers and other settings are changed.	<ul style="list-style-type: none"> ● Check the method used to operate the remote controller. ● Check the settings of the remote controllers 1 to 5. If the remote connector is unconnected, the monitor will judge it to be open (remote switch at OFF).
The power does not come on.	<ul style="list-style-type: none"> ● Turn the power off, wait for a few moments (about 3 seconds), and then turn it back on.
Something is wrong with the image quality.	<ul style="list-style-type: none"> ● Press the MENU switch to select PICTURE QUALITY, and check whether something is wrong with the settings.
Operations from the RB-1666 (infrared remote controller) are not acknowledged.	<ul style="list-style-type: none"> ● Does the product support infrared signals? The DM-3016-F supports these signals. Although the DM-3016 does not differ significantly from the DM-3016-F in appearance, it does not support infrared signals. ● Has the ID been set correctly? ● Check the distance between the DM main unit and RB-1666 and the angle at which they are placed. If the distance between them is too great, the infrared signals will not reach the main unit. In addition, the signal coverage differs depending on the angle. ● Are there any obstructions between the DM main unit and RB-1666? If the front of the infrared sensor is blocked by an obstruction, this will interfere with the passage of the signals which will not reach the main unit.

No trouble or malfunctioning is indicated if any of the following situations should occur.

These situations arise due to the nature of liquid crystal.

- **The response time, brightness and/or colors of the liquid crystal may change depending on the ambient temperature.**
- **Unevenness in the brightness, flicker, vertical stripes or very small indistinct spots may appear depending on what is displayed.**
- **Flicker may be conspicuous when the LCD display frequency is 50 Hz, 48 Hz or 47.95 Hz compared with when it is 60 Hz or 59.94 Hz.**
- **The display's optical characteristics (brightness, display unevenness, etc.) change depending on the operating time. They are particularly subject to change at low temperatures.**
- **The display colors may change at certain view angles.**
- **Noise may be generated on the start screen.**
- **After-images may occur. Avoid displaying the same patterns on the screen for prolonged periods of time.**
- **Horizontal stripes may become conspicuous on the display if a significant amount of peaking is applied with an aspect ratio setting of 16:9 and with 1080i input signals.**

When trouble or malfunctioning occurs

- **In the unlikely event that trouble or malfunctioning should occur, contact your dealer or an Astrodesign sales representative.**
- **If trouble should occur in the LCD panel, the user will be charged for repairs and parts replaced even within the warranty period.**

NOTICE

An incorrectly collated manual or a manual with missing pages will be replaced.

All copyrights pertaining to this product are the property of Astrodesign.

This manual may not be used or copied in whole or in part without permission.

The contents of this manual are subject to change without prior notice due to improvements.

The manufacturer will not be liable for any outcome which results from the incorrect operation of the product.

All inquiries concerning this product should be addressed to your dealer or to the manufacturer at the contact numbers given below.

The products and product names mentioned in this manual are the trademarks and registered trademarks of the companies concerned.